

# arflex

69  
YEARS  
DESIGN  
MADE IN  
ITALY

<<Let's sit down for a  
moment..>>

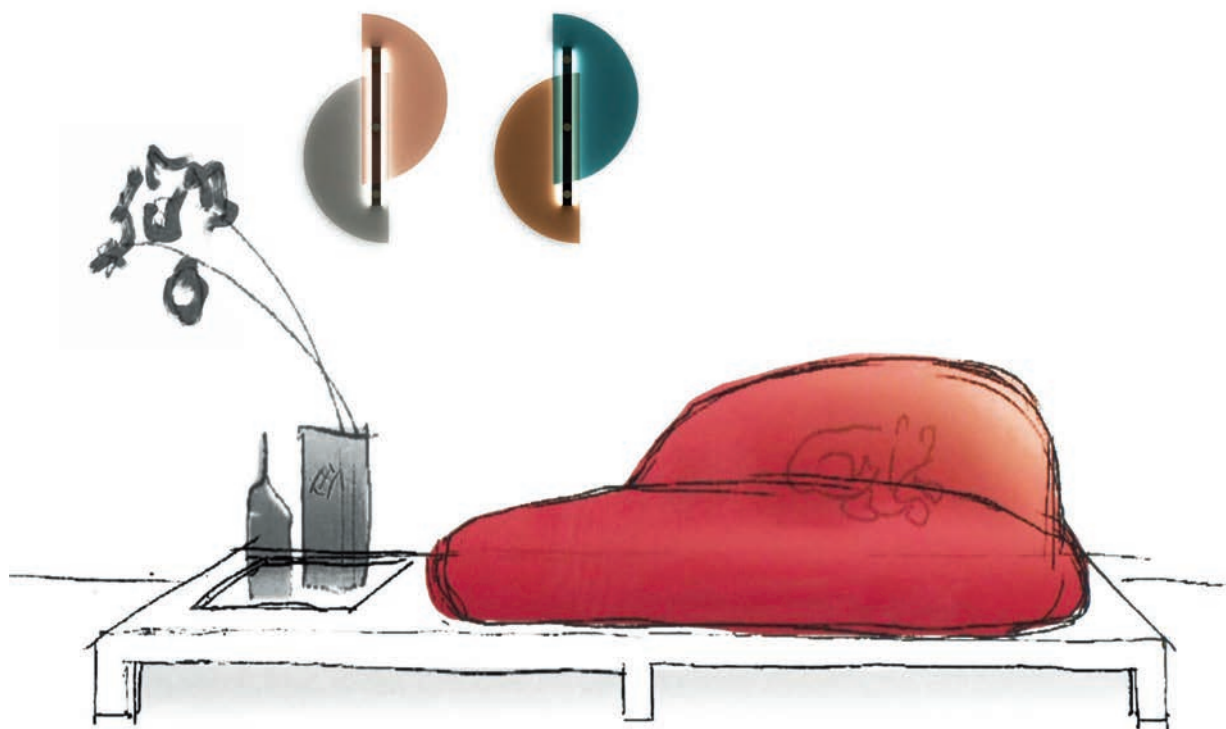

# INDEX

## SOFAS

BEN BEN	121
BOBO DIVANO	125
BONSAI	41-43-45
CANDY	223-225
CHARLES	241
CLAUDINE	211-213-215
COUSY	175-177
DANDY	229
FAUBOURG	189-191
FELIX	261
FRAME	179-181-183-185-187
HALL	25-29
HOLLYWOOD	201-203-205-207-209
HUG LOVE SEAT	141-143
ITACA	245
K2	171-173
KNP	71-73
MANGOLD	3-5-7-9-11-13
MARECHIARO XIII	163-165-167-169
MARENCO	117-119
NAVIGLIO	233-235-237-239
PAPOOSE	57-59-61-63
RENDEZ-VOUS	15-17-19-21-23
SENNA	247
SOFT BEAT	217-219
STRIPS	99-101-103-105

## ARMCHAIRS

ALGON	145-147
ARMILLA	254
BOBORELAX	123
BOTOLO	91-93
BUTTERFLY	257
COCCA	197-198
CROSS	47-49-51
DELFINO	67-69-85
ELETTRA	73-125-127-163-247
FIorenZA	115-196
GINA	97-221-241
GIULIETTA	53-55
JIM	37-39-49
JULES	31-33-35
HALL	24-27
HUG	2-9-109-137-139
KATRIN	258
LADLE	149-157-159-161
LIPS	252
MOJO	255
PECORELLE	95-97
PENTA	227
SELLA	251
SERENA&DOGE	193-195
TABOGA	243
VIRGOLA	259

## CHAIRS

BLISS	75-77
BOTOLO	91-93
COROLLE	81-83
ELETTRA	129-131
HUG	135
NEPTUNIA	79

## BEDS

JOY	269-271
LEDLETTO	273
PALAZZO	265
SUITE	267

## TABLES

HUG TABLES	135
MATCH	89-130
OCTOPUS TABLE	129-132

## SMALL TABLES AND FURNITURE UNITS

BONSAI	19-23-41
CAPILANO	65
DIVA	59-69-109-149
FILU'	47-190-229-231
HILLSIDE	113-115
HUG	133-169
ISLAND	166-225-249
MANGOLD	5-39
MATCH	43-85-87-219
OCTOPUS	177-256
PONTI	49-131-141-155
RUBYCON	107-109-111-145
TABLET	183-199-211-213
VELA	151

## LAMP

PAPILLON	153
----------	-----

## OUTDOOR

CLOUD COLLECTION	263
------------------	-----

# >MANGOLD

design CLAESSION KOIVISTO RUNE



Mangold sofa composition MG01, Hug armchair with high backrest, Island small table, Tablet small table.



Mangold sofa composition MG02, Jules armchair, Tablet small table.



5 #arflex



Mangold small table.



Mangold furniture armrest.



MG04



MG05



MG06



MG07



MG07



MG08



MG09



MG10





Mangold sofa composition MG16, Match small table, Tablet small table, Doge pouf, Hug smaller side armchair, Match console.







Mangold sofa composition MG14 with armrest, Island small table, Botolo armchair, Tablet small table, Doge pouf, Jules armchair, Cross armchair.



Mangold sofa composition MG15, Match small table, Tablet small table, Doge pouf.



# > RENDEZ-VOUS

design Mauro Lipparini

Serenità, semplicità, matericità, componibilità sono alcune delle parole chiave di Rendez-vous. Il suo rigore formale complessivo è accompagnato dall'esuberanza delle morbidezze interne,

come a cercare di abbracciare e assecondare il corpo e la piacevolezza del comfort. La possibilità di comporre liberamente e in modo articolato le configurazioni di aggregazione sono una risposta al passo coi tempi, pur non tralasciando i valori della tradizione, così da reinterpretarle in chiave di evoluta contemporaneità, sia estetica che funzionale.

Il divano ha la struttura in legno e l'imbottitura in poliuretano sagomato a densità differenziata e poggia su piedini in metallo laccato nero o su una base a "fascia", in metallo laccato nero, brunito o nichel nero.

Serenity, simplicity, materiality, modularity are some of the key words of Rendez-vous. Its overall formal rigor is accompanied by the exuberance of the inner softness, as trying to hug and hold the body and the pleasure of comfort. The possibility to freely compose and articulately create the seat composition are a response in line with the times, without forgetting the values of the tradition, so as to reinterpret them in a contemporarily and evolved key, both aesthetic and functional.

The sofa has a wooden frame and the upholstery in shaped polyurethane foam with differentiated density and lies on feet in black metal or on a band basis, in metal lacquered black or burnished or nickel-plated black.





Rendez-vous sofa composition R01.



Rendez-vous sofa composition R05, Bonsai small table, Tablet small table,  
Match console.





Rendez-vous sofa composition R05, Capilano small table, Botolo armchair.





Rendez-vous sofa composition R05, Papoose sofa, Hall armchair, Bonsai small table, Capilano small table, Papillon wall-lamp.





# > HALL

design ROBERTO MENGHI

Siamo alla fine degli anni '50: un' interessante serie di poltrone e divani, disegnata da Roberto Menghi e denominata Hall entra a far parte della collezione arflex.

Sono anni dove il design tende a non essere più soltanto di élite. La nascita di altre riviste sulla scia di Domus, la Triennale, le mostre specializzate riescono a sensibilizzare fasce più larghe di distributori e di pubblico. La poltrona Hall riceve nel 1959 la menzione d'onore per il Compasso d'oro.

La struttura e i braccioli della poltrona e del divanetto sono realizzati in metallo e rivestite in poliuretano sagomato.

Il basamento è in legno, laccato wengé, cioccolato e RAL 3016.

We are at the end of the '50s: an interesting series of armchairs and sofas, designed by Roberto Menghi and called Hall joins arflex collection.

In these years the design tends not to be only for "élite". The birth of other magazines in the wake of Domus, Triennale, the specialized exhibitions manage to raise wider layers of distributors and audience. The armchair Hall receives in 1959 the honorable mention for the Compasso d'Oro.

The frame and the armrests of the armchair and of the sofa are realized in metal and covered in shaped polyurethane foam.

The base is made of wood, stained wengé, chocolate or RAL 3016.



Hall armchair, Tablet small table, Bonsai small table, Match console, Papillon wall-lamp.

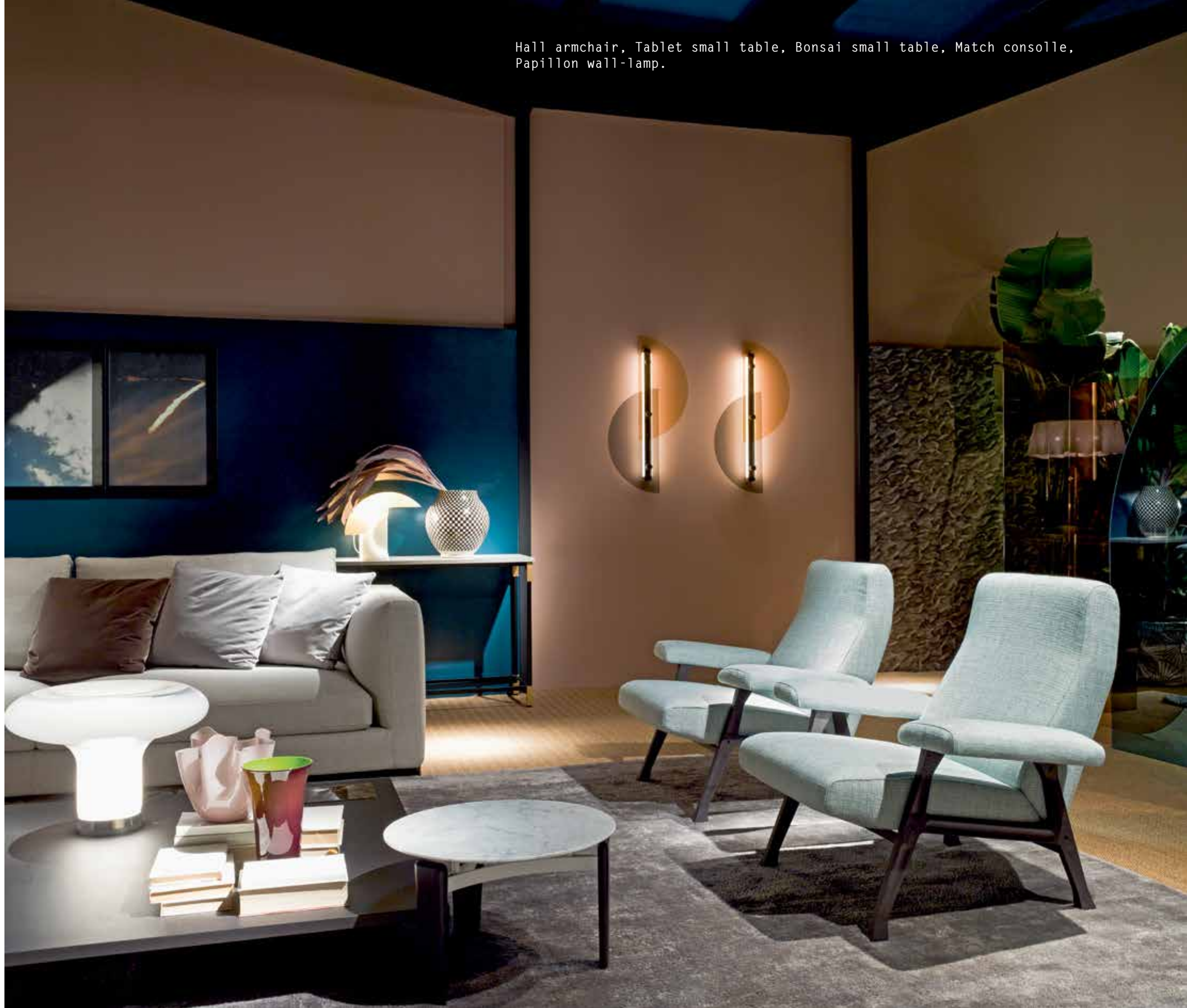





Hall sofa, Match bookcase.



# >JULES AND JIM

design CLAEISSON KOIVISTO RUNE

I nomi derivano dal famoso film francese di Francois Truffaut. Jules & Jim sono due poltrone semplici, con un alto comfort di seduta. Jules è la versione piccola e Jim la versione più larga. Nonostante la differenza di grandezza, le due poltrone condividono la stessa forma (geometrie rotonde), che le rende facili da usare e da ambientare in un contesto architettonico, dove magari tipologie di sedute squadrate sono più difficili da introdurre. L'abbinamento delle gambe in legno e metallo rendono possibili la personalizzazione delle diverse finiture e quindi Jules & Jim possono essere posizionate in qualsiasi contesto. Named after the famous French movie by Francois Truffaut, Jules & Jim are two easy chairs with a high degree of seating comfort. Jules is the smaller one and Jim the larger one. Though different in size they share a round geometry, which makes them easy to use and place in an architectural context, where maybe more square seating typologies are difficult to use. The legs in wood and metal are also easy to customize in various finishes, so that Jules & Jim can be matched to fit any furnishing context.



Jules armchair, Match bookcase.



Jules armchair, Match bookcase.









Claudine sofa composition  
CLL03, Jules armchair,  
Tablet small table.



Jim armchair.



Jim armchair, Tablet small table.



Mangold sofa composition MG09, Jim armchair, Mangold small table.



# >BONSAI

design CLAEISSON KOIVISTO RUNE

La collezione Bonsai si ispira alla riflessione sull'estetica e sulla cultura giapponese. Le sedute sono caratterizzate da forme morbide e curve. Queste forme invitanti e accoglienti sono reminiscenze dei cespugli e delle piante, che si trovano nei giardini di tutto il Giappone, che sono stati coltivati e potati per creare delle forme graziose, morbide, naturali, che ricordano le nuvole. In forte contrasto, sono le piattaforme lineari, realizzate in legno, che lo supportano e le gambe in legno, che sollevano queste forme tonde ed imbottite dal pavimento. Quasi come tokonoma, dove si posizionano gli oggetti preziosi, come un albero bonsai, su una superficie orizzontale per creare uno spazio interno, le piattaforme creano una sorta di struttura più piccola e riservata, in un contesto più largo. All'interno di questa "struttura" c'è la presenza di altri elementi, come la lampada opzionale integrata con una copertura in tessuto e un piano in marmo o specchio, per appoggiare dei fiori o semplicemente una pila di libri. Le sedute imbottite in poliuretano schiumato in stampo sono disponibili con basamento, realizzato in legno, tinto wengé, rovere o cioccolato, oppure sollevate da piedini in metallo, laccato nero.

The Bonsai seating collection is inspired by reflections upon Japanese aesthetics and culture. The seats are characterised by soft, curved forms. These inviting, friendly shapes are reminiscent of the bushes and shrubs, found in gardens all over Japan, that have been cultivated and trimmed in order to create beautiful soft, 'organic', cloud-like shapes. In stark contrast, rectilinear wooden platforms supported on low, wooden legs elevate these rounded, upholstered forms above the floor plane. Almost like tokonoma, the practice of placing selected, cherished items such as a bonsai tree, upon a horizontal surface in order to create an interior feature, the platforms create a kind of smaller, more dedicated frame within a larger context. Within this 'frame' is the presence of other elements such as an optional integrated lamp with a flowing fabric shade and a recessed stone or mirror plate, for arranging potted plants on or simply a stack of books. The upholstered seats in moulded polyurethane foam are also available with the platform, realized in wood, painted wengé, oak or chocolate, or supported on simple legs, in black metal.



Bonsai sofa with wooden base, Bonsai pouf with wooden base, Bonsai small table.



Bonsai sofa with wooden base, Rubycon cabinet, Match small table, Jim armchair.





Bonsai sofa with metal base.



Bonsai sofa with metal base.

# >CROSS

design MARCELLO CUNEO

Arflex riedita dal suo archivio storico la poltrona Cross, progettata dall'architetto Marcello Cuneo nel 1974. La seduta nasce da un'idea molto semplice: due tubi a U collegati tra loro mediante un giunto; sulle due strutture, fodere di tela fanno da sostegno portante ai due cuscini di seduta e schienale. L'architetto Cuneo con questa idea intuitiva ha avuto una menzione d'Onore all'XII Compasso d'Oro del 1979.

Arflex makes from its historical achieve the re-edition of the armchair Cross, designed by the architect Marcello Cuneo in 1974.

The seat is born from a very simple idea: two tubes bent into a U shape and linked together by a light alloy joint. On the two structures the covers (made by thick fabric, that has also load-bearing function) are slipped into and carry the cushions of the seat and backrest. The architect Cuneo had a special mention at XII Compasso d'oro, in 1979, for this intuitive idea.



Cross armchair, Filù bookcase.





Cross armchair, Jim armchair,  
Delfino pouf, Ponti writing desk.

Papoose sofa, Cross armchair, Diva screen.



51 #arflex



Cross armchair.



# >GIULIETTA

design B.B.P.R.

Il design anni 50 nasce in un periodo dove l'Italia aveva voglia del riscatto dal dopoguerra. I progettisti (non ancora chiamati designer) e le aziende creavano prodotti per infondere speranza e buonumore alle persone. Belgiojoso, Peressutti e Rogers dello studio B.B.P.R. progettaron la poltrona Giulietta, con tutte le caratteristiche che distinguevano la produzione arflex: studio approfondito della linea e assoluta comodità, senza tralasciare l'eleganza. Con questo modello, conquistarono la copertina della rivista Domus. (N.372 - Novembre 1960). The 50-year design born at a time when Italy wanted redemption after the war. The design architects (not yet called designer) and the companies created products to inspire hope and good humor to people. Belgiojoso, Peressutti and Rogers of B.B.P.R. office designed the armchair Giulietta, with all the characteristics of the arflex production : depth study of the line and absolute comfort, without forgetting the elegance. With this model they won over the cover of the magazine Domus (no. 372 - November 1960).



Giulietta armchair, Match small table.







# > PAPOOSE

design LUCA NICHETTO

Papoose (letteralmente marsupio per bambini) è un sistema modulare, composto da diverse basi divise per due e tre sedute con una selezione di differenti schienali.

La combinazione delle basi e degli schienali dona la possibilità di creare un gran numero di varianti, che consentono a Papoose di adattarsi sia all'ambiente residenziale che al mondo contract.

La struttura realizzata principalmente in poliuretano sagomato a densità differenziata, può essere rivestita con tessuti o pelli e viene arricchita da dettagli sartoriali, che evidenziano la sua estetica morbida.

Schienale e bracciolo contengono all'interno i cuscini, che quando sono rovesciati aumentano il comfort del divano.

Papoose (literally papoose for children) is a modular sofa system, composed of three different bases divided in one, two and three-seat and with a selection of several backrests.

The combination of the bases and backrests gives the possibility to create a large number of variants, allowing to adapt Papoose mainly to the home environment, but also to some contract setting.

Composed primarily of shaped foam in different density, Papoose can be dressed by fabrics or leathers, tailored to the sofa, enriching it with tailored details that highlight its soft aesthetics.

Backrest and armrest contain the pillows inside, that when tipped over in front the back structure increase the comfort of the sofa.



Papoose sofa composition P02.





Papoose sofa, Filù small table, Ponti writing desk.



61 #arflex



Papoose sofa.





# >CAPILANO

design LUCA NICHETTO

Supportato da una struttura leggera ed elegante in metallo, la serie di tavolini Capilano prendono il nome dal ponte sospeso Capilano a Vancouver. Sviluppati originariamente come completamento del divano Papoose, disegnato nel 2015, Capilano sono una serie di tavolini stand-alone, disponibili in due diverse configurazioni: triangolare e rettangolare. Mentre la struttura è in metallo laccato nero, il top è realizzato con lastra ceramica high-tech di alta qualità, con una superficie liscia e resistente.

Supported by a light and elegant metal frame, the Capilano small table system takes its name from the Capilano Suspension Bridge in Vancouver. Originally developed to complement the Papoose sofa, designed in 2015, Capilano is a stand-alone series of small and side-tables available in two different configurations: triangular and rectangular. While the frame is metal, black lacquered, the table top is made by a high-tech ceramic tile, with a smooth and resistant surface.



Algon lounge chair, Capilano small table.



# > DELFINO

design ERBERTO CARBONI

La collezione arflex si arricchisce di un altro pezzo storico disegnato da Erberto Carboni. L'idea non nasce per il semplice gusto della riedizione, ma piuttosto per la linea ancora modernissima, la funzionalità e il grande confort. La poltrona è un esempio significativo del filone di arredamento cosiddetto "organico" che si sviluppa negli anni cinquanta e che trae ispirazione dalle forme della natura, senza cadere nell'equivoco imitativo. Il bracciolo come pinne, il corpo armonico e flessuoso come quello di un delfino: da questo simpatico mammifero marino prese infatti il nome. Nella poltrona Delfino riconosciamo il grande segno grafico di Erberto Carboni. Arflex collection increases with another historical piece, designed by Erberto Carboni. The idea is not born from the simple taste of the re-release, but from the line still modern, the function and the great comfort of Delfino. Delfino is a significant example of the so-called "organic" furniture which develops in the fifties and which often draws its inspiration by the nature, avoiding any imitation. The product is considered as an unitary structure without discontinuance, a group of following shapes which give to the body a continual support with their sinuous lines. The development of this concept gave a very decorative result and produced items, like Delfino, with a strong personality. With arm like fins and a harmonious, supple body like a dolphin, this armchair took its name from the graceful sea-mammal. In the armchair Delfino we can see the great graphic sign of Erberto Carboni.







Delfino armchair,  
Tablet small table,  
Diva screen.

# > KNP

design JEAN NOUVEL

KNP: interrogazione sull'archetipo del divano, reinterpretazione delle tecniche di oggi, per proporre un altro modo di abitare, di posarsi, di amarsi, di arrotolarsi, di separarsi : fabbricarsi "un nido"... Gli ingredienti di KNP riprendono le tecniche di base dell'atelier di Arflex : struttura in legno Okumé, materassino in poliuretano per il comfort, coperte reversibili e ampie, realizzate all'infinito con delle zip. Le forme fuori norma e ampie delle strutture sono ricoperte da grandi drappi bicolore. I tessuti sono tecnici, morbidi e sensuali, suggerimento di libertà e di stare bene, di movimento, di manipolazione e di rilassamento. Jean Nouvel immagina KNP spiritoso, rilassante, generoso. KNP è naturalmente multiforme, reinventato da ciascuno con il gioco di sovrapposizione dei materassini, dall'insieme delle coperture a drappo.

KNP: question on the archetype of the sofa, reimagining nowadays techniques, to propose a new way to live, to rest, to love, to roll, to keep apart: to make a "nest"... The ingredients of KNP revive the base techniques of Arflex atelier: structure in Okumé wood, mattress in polyurethane for the comfort, wide and reversible covers, realized with zips endlessly. The wide and non standard shapes of the structures are covered with big bi-coloured cloths. The fabrics are technical, soft and sensual, suggestions of freedom and feel good, of movement, manipulation and relaxation. Jean Nouvel imagines KNP funny, relaxing, generous. KNP is naturally multiform, reinvented by everyone with the game of overlapping the mattresses, with the set of the drape covers.



KNP sofa, Filù small table.



KNP sofa, Elettra armchair, Botolo armchair, Filù small table,  
Tablet small table.

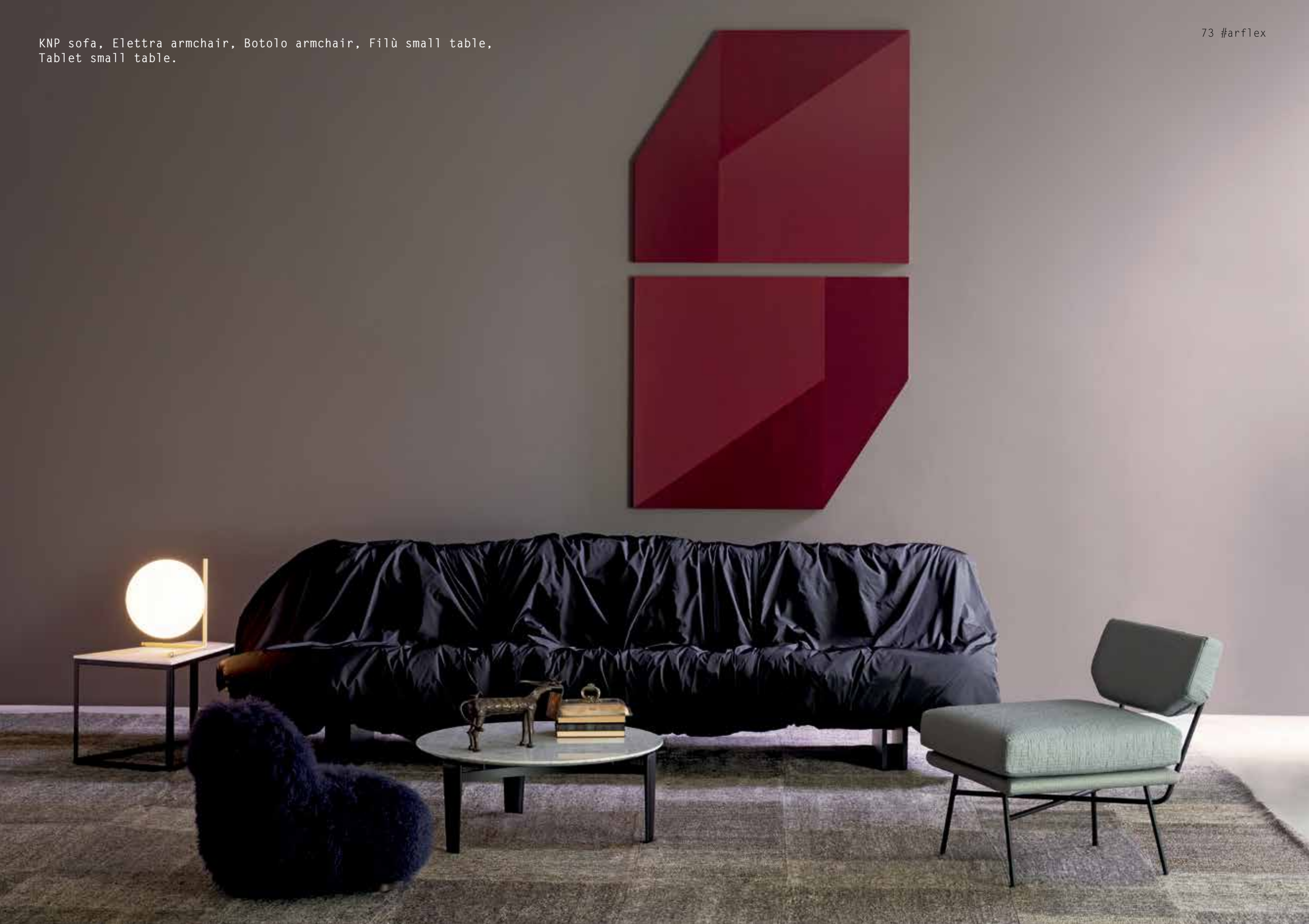

# >BLISS

design MARIO RUIZ

L'identità di Bliss è costituita dalla forma arrotondata. I profili curvi e i diversi componenti sottili creano un unico corpo irregolare e delicato, così da ottenere un pezzo di grande leggerezza visiva e di grande comfort. Bliss è una poltroncina che abbraccia il corpo di chi si siede, permettendogli di giocare con i colori e i tessuti nelle varie parti che la compongono (schienale, sedile, braccioli). L'utilizzo è stato pensato sia per la casa che per l'ufficio; per questo motivo sono state progettate la base in legno e la versione in "metallo" a quattro razze.

The identity of Bliss is constituted by the rounded shape. The curved profiles and the different light components create an unique, irregular and delicate body, so that to obtain a piece of great visual lightness and great comfort. Bliss is an armchair that embraces the body of one who sits on it, allowing him to play with the colors and the fabrics of the different parts that make it up (backrest, seat, armrests). The use is designed for both home and office; for this reason, it is realized the wooden base and the "metal" spoke version.







Bliss armchair.



Bliss armchair, Ponti writing desk.



# > NEPTUNIA

design B.B.P.R

La sedia Neptunia viene disegnata negli anni '50, come da un tratto continuo della serie Elettra, per dare ampia scelta nella progettazione di uffici e spazi pubblici. La serie Neptunia riprende le forme morbide ed accoglienti e le proporzioni della serie Elettra, mantenendo le linee pure e sorprendenti del design anni'50. I braccioli gli conferiscono una forma avvolgente, che riassume l'eleganza formale e il comfort ideale per un ambiente domestico e spazi hospitality.

La seduta e lo schienale sono in poliuretano schiumato in stampo e appoggia su gambe in metallo laccato nero.

Neptunia chair, was designed in the '50s, as a continuation of the Elettra collection, for giving choice to design offices and public spaces.

Neptunia resumes the soft and welcome shape and the proportions of Elettra series, keeping the pure and amazing lines of the '50s design. The armrests give a snug fit, that summarizes the formal elegance and the ideal comfort for home environment and hospitality spaces.

The seat and the backrest are in moulded polyurethane foam and lies on legs, realized in black metal.



Neptunia smaller side armchair, Match table, Papillon wall-lamp.



# >COROLLE

design MARIO RUIZ

Come un fiore, la sedia Corolle ha un corpo sottile e avvolgente. Mario Ruiz progetta la sedia Corolle, dove i volumi sono l'essenza del design contemporaneo. Il sedile e lo schienale formano un'unica scocca dalle dimensioni e disegno ben definito.

La struttura, realizzata in poliuretano rigido ricavata da un unico stampo, può essere arricchita da cuscini di seduta e schienale, in poliuretano sagomato e poggia su gambe in metallo laccato, cromato o dorato, con un work in progress, per dare più possibilità di collocazione, sia in ambienti domestici che di collettività.

Like a flower, the Corolle chair has a fine and embracing shape. Mario Ruiz designs the Corolle chair, where the volumes are the essence of the contemporary design. The seat and the backrest create a unique body, with dimensions and design very well defined. The frame, realized in rigid polyurethane obtained from an unique mould, can be improved by cushions for seat and backrest in shaped polyurethane foam and is placed on legs, in metal, lacquered, chromed or golden, with a work in progress, in order to give more possibilities to use the chair in home and community spaces.



Corolle chair, Match table, Papillon wall-lamp.





# >MATCH

design BERNHARDT&VELLA

Il progetto nasce da un sistema di scaffalature industriali. Lo snodo che assembla la struttura con il piano diventa un elemento prezioso e decorativo in ottone o brunito. Il sistema impilabile permette di creare con gli stessi elementi tavolini e librerie di varie altezze, consolle e tavoli. I ripiani delle librerie sono realizzate in frassino laccato cioccolato, mentre il top dei tavolini, della consolle e il piano dei tavoli sono disponibili in marmo.

La struttura tubolare è laccata nero opaco.

The project is born from an industrial shelves system. The junction, that joins the structure with the shelf, becomes a precious and decorative element in brass or burnished. The system can be stacking and allows to create with the same elements small tables and bookshelves with different heights, consolle and tables. The shelves for the bookcases are in ash, chocolate lacquered; the small tables tops, the consolle and the tables top are available in marble. The tubular frame is black matt lacquered.



Delfino armchair, Botolo armchair, Island small table, Match bookcase.





Pouf, Match consolle.



Match small tables, Match consolle.



Hug love seat sofa, Bliss armchair, Match table.



# > BOTOLO

design CINI BOERI

bo...bo... bobo, anno 1967 arflex  
bo...bo... boborelax anno 1969 arflex  
bo...bo... botolo anno 1973 arflex  
bo...bo... botolorelax...opening soon!  
bo...bo...bobo, year 1967 arflex  
bo...bo...boborelax year 1969 arflex  
bo... bo...botolo year 1973 arflex  
bo...bo...botolorelax...opening soon!







Botolo armchair, Match table.

Claudine sofa, Botolo armchair, Island small table.



# > PECORELLE

design CINI BOERI

Dall'evoluzione del divano Strips, nascono anche "Pecorelle", una variante costituita da poltrona e divanetto, dove il corpo viene posizionato su esili gambe nere, che ricordano appunto le pecorelle. L'arch. Cini Boeri racconta che fu ispirata dalle opere di Christo Vladimirov Javasev e Jeanne-Claude Denat de Guillebon, maestri nell'arte della pittura di paesaggio. La natura prende così il sopravvento ed è la musa ispiratrice di questo nuovo pezzo di design. "Le pecorelle sono un po' cresciute, ed anche si sono imbarcate per l'America! Un bel record per delle pecore ...sta cambiando il mondo!" Cini Boeri 2010.

From the evolution of sofa Strips, we have "Pecorelle", a version consisting of armchair and small sofa, where the body is positioned on thin black legs, that remember exactly the sheep. Arch. Cini Boeri tells that she was inspired by the works of Christo Vladimirov Javasev and Jeanne-Claude Denat de Guillebon, masters in the the art of landscape painting. Nature prevails and becomes the inspiring muse of this new piece of design. "Pecorelle have grown up and they have sailed for America! A nice record for some sheep...world's changing!" Cini Boeri 2010



Pecorelle sofa, Pecorelle armchair.



Gina armchair, Pecorelle armchair, Island small table.



Pecorelle armchair.



# >STRIPS

design CINI BOERI

Agli inizi degli anni 70 l'arch. Cini Boeri ha rivoluzionato il settore del mobile con il suo pezzo che è rimasto ormai un "evergreen", il divano componibile Strips che appartiene alla storia di arflex. Sicuramente uno dei prodotti più famosi, disegnato nel 1972, ha guadagnato il riconoscimento del premio Compasso d'oro ed è esposto in vari musei nel mondo, come alla Triennale di Milano, a Tokyo, al Moma di New York, etc. il prodotto è caratterizzato da una fodera trapuntata completamente sfoderabile e disponibile anche nella versione letto e divano-letto. La modularità consente infinite combinazioni. L'arch. Cini Boeri ha sempre cercato di realizzare idee innovative in modo da poter migliorare la qualità della vita. Questa idea è stata applicata soprattutto allo Strips letto, dove il rivestimento diventa parte integrante del letto: con una semplice cerniera, il letto viene coperto e rifatto, aggiungendo soltanto il cuscino. Anche nel divano, le imbottiture sono parte integrante del rivestimento, posizionate su un'anima di legno, imbottitura con poliuretano (indeformabile) per poter garantire maggior comfort di seduta: tutti materiali innovativi, utilizzati nel settore per le prime volte.

At the beginning of the seventies Arch. Cini Boeri revolutionized the furniture market with a product range, nowadays an "evergreen": the modular sofas Strips, which belong to the history of arflex. It deals of one of the most famous products, designed in 1972, which awarded the prize Compasso d'Oro and it is displayed in several museums in the world, like the Triennale in Milan, in Tokyo, Moma in New York, etc...The main characteristic is a removable quilted cover. Available also as bed and as sofa-bed allows countless combinations. Arch. Cini Boeri always tried to realize innovative ideas to improve the quality of life. This idea was applied to the Strips bed, where the cover becomes part of the bed itself: by opening a simple zip, the bed is ready, only a pillow must be added. Also for the sofa, the padding are an integral part of the cover, positioned on a wooden frame, same are in non-deformable polyurethane foam, to guarantee the best comfort of the seat: all innovative materials, used for the first time in the furniture market.



STRIPS sofa-bed.



Strips sofa composition S7.



Strips sofa composition S3.







Strips sofa composition S14.



La famiglia degli Strips design Cini Boeri, composta da divani, poltrone e letti, si arricchisce della poltrona "lunga" per i freddolosi.

La seduta è allungata, mentre la trapunta è apribile con una cerniera, diventando una coperta, per un grande comfort quando si vuole riposare, rilassarsi, riflettere al caldo.

Strips family, composed by sofas, armchairs and beds, designed by Cini Boeri, develops with chaise longue, for people, who feel the cold. The seat is longer and the cover can be open with zip, becoming a blanket, for a complete comfort, for sleeping, relaxing, thinking in a warm place.



# > RUBYCON

design CLAESSION KOIVISTO RUNE

Minimalismo nella forma, massima varietà di espressione. Il concetto di Rubycon permette la creazione di contenitori unici e free-standing, attraverso la personalizzazione, dando anche la possibilità di avere pezzi decorativi e laccati in tonalità oppure in contrasto, a seconda di dove vengono posizionati. Il concetto di Rubycon usa la ripetizione di un singolo contenitore cubico per creare una colonna orizzontale, con cinque diverse lunghezze. Le colonne a cubo poggiano leggermente su una struttura sottile con delicati elementi di unione. Ogni contenitore cubo può essere utilizzato a seconda delle diverse necessità. I contenitori Rubycon derivano il loro nome dalla stretta relazione tra ogni cubo e il suo vicino. Questi cubi semplificati, disegnati senza maniglie o pomelli a vista, possono sembrare nel loro insieme come un dipinto tridimensionale. Il cliente ha la possibilità di scegliere tra una varietà di colori e di essenze, per personalizzare il suo dipinto vuoto. Il concetto Rubycon lascia completa libertà al cliente nella scelta delle finiture, disponibili nelle varie essenze e laccature della collezione arflex, permettendogli di creare un mobile che è grafico o discreto, a seconda delle situazioni. Il basamento è in metallo laccato nero o dorato, solo per la madia a due moduli.

Minimal form, maximum variety of expression. The Rubycon concept allows the creation of unique, free-standing cabinets through customisation, giving the possibility for making eye-catching, focal pieces that are in tune, or in contrast, with the particular interior into which they are placed. The Rubycon concept uses the repetition of a single storage 'cube' to create a horizontal column in five different lengths. The 'cube columns' rest lightly on a thin steel leg frame with delicate joints. Each storage 'cube' can be purposed for a variety of storage needs. The Rubycon cabinets gain their expression from the relationship between each cube and its neighbours. These simplified 'cubes', designed without visible handles or knobs, can be understood collectively as a three-dimensional blank canvas. The client has the possibility to choose from a range of painted colour options as well as various wood finishes to customise their 'blank canvas'. The Rubycon concept places the freedom of choice of the finishing, available in the different wood and colors of arflex collection, into the hands of the customer, allowing them to create a furniture piece that is as graphic or as subtle as the situation demands. The base is in metal, lacquered black or golden, only for the cabinet with two cubes.





Rubycon cabinet, Diva screen, Hug armchair with high backrest.



Rubycon cabinet, Frame sofa.



111 #arflex





# >HILLSIDE

design CLAESSION KOIVISTO RUNE

Elettra chair, Hillside furniture unit, air version.

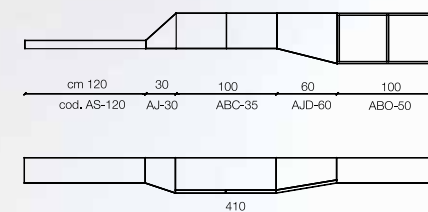

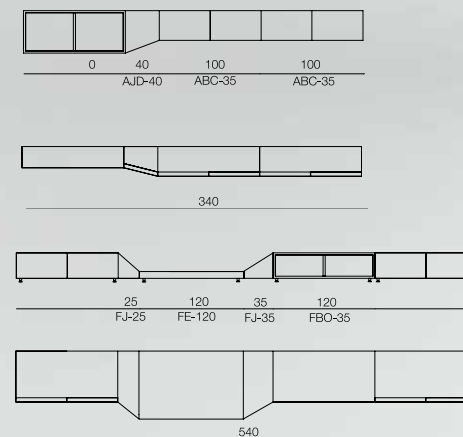

Fiorenza armchair, pouf, Hillside furniture unit, air and floor version.



# >MARENCO

design MARIO MARENCO

Marenco sofa, Marenco pouf.







# > BEN BEN

design CINI BOERI



Ben ben sofa composition B3.



# > BOBORELAX

design CINI BOERI

Bobo, disegnato da Cini Boeri nel 1967, è uno dei primi esempi di un sedile monoblocco realizzato esclusivamente con schiume poliuretaniche e privo di struttura interna. Bobolungo, Boboletto e Boborelax nati dalla costola di Bobo, costituiscono con questo un'insolita e curiosa famiglia di arredi essenziali, un esempio di design puro, senza etichetta e senza aggettivi. Bobo Divano nato dal predecessore Boborelax del 1967, il cui design era scaturito dalla ricerca di una forma plastica monoblocco, è realizzato con l'impiego di schiume poliuretaniche espanse a densità graduata, nella quale non esiste alcuna struttura rigida interna.

Bobo, designed by Cini Boeri in 1967, is one of the first examples of a monobloc seat made exclusively of polyurethane foam, without an internal frame. Bobolungo, Boboletto and Boborelax created from Bobo, make up a curious and unusual family of essential furnishings, an example of pure design, without etiquettes and adjectives. Bobo Divano was born from the previous Boborelax of the year 1967, whose design came out from the research of a monobloc plastic shape. It is manufactured using polyurethane foams in differentiated density, without an internal rigid frame. The design expresses plastically the research of synthesis and continuity of the shape.







Bobo divano sofa, Elettra armchair.

# >ELETTRA

design B.B.P.R.





> ELETTRA

design B.B.P.R.

> OCTOPUS

design CARLO COLOMBO







Elettra chair, Match table, Pecorelle armchair.

Ponti writing desk, Elettra chair.





Elettra chair, Octopus table.

>HUG small table  
design CLAEISSON KOIVISTO RUNE



Hug armchair with high backrest, Hug small table.

> HUG table  
design CLAEISSON KOIVISTO RUNE



Hug smaller side armchair, Hug table.

Hug smaller side armchair, Hug table.





# > HUG

design CLAESSION KOIVISTO RUNE



Hug smaller side armchair, Hug armchair, Hug armchair with high backrest.





# > HUG LOVE SEAT

design CLAEISSON KOIVISTO RUNE

Hug love seat crea la cornice per un luogo comodo e rilassante, che protegge dalla frenesia della vita. E' un divano dalle misure contenute, per creare nella propria sala una zona di relax confortevole, che invita a sedersi, rilassarsi e abbracciarsi.

Hug love seat creates a frame for a comfortable and relaxing place, which protects from the frenzy of life. It's a sofa with reduced sizes, to create a comfortable relax area in the own living room, which invites to sit, relax and embrace.



Hug love seat sofa, Hug love seat sofa with high backrest.



Hug Love seat sofa with high backrest, Cross armchair, Ponti writing desk.



Hug love seat sofa, Bliss armchair, Match table.



# >ALGON

design LUCA NICHETTO

L'Algon lounge Chair è stata sviluppata contemporaneamente all'Algon Chair, mescolando la semplicità scandinava con l'imbottitura trapuntata. A differenza della Algon Chair che ha una forma rigorosa, l'Algon lounge Chair ha i bordi alti, che consentono di avere la necessaria privacy ed è perfetta per una silenziosa conversazione notturna o per un momento solitario di tregua. Come per il divano Papoose, presentato nel 2015, il nome Algon si ispira alle tribù nord americane Algonquian.

Entrambe le strutture delle poltrone sono realizzate in poliuretano schiumato in stampo. Il rivestimento interno può essere arricchito da una trapunta, che dona una piacevole sensazione di accoglienza; il cuscino di seduta è in poliuretano sagomato a densità differenziata. Le sedute rimangono sollevate da terra grazie ai piedini, in metallo laccato nei colori della collezione arflex oppure nichel nero.

The Algon lounge Chair was developed together with the Algon Chair, melding Scandinavian simplicity with a patterned quilted upholstery. Contrary to the Algon Chair, that has a strict formality, the Algon lounge chair has high sides, that allow for a sense of privacy, perfect for hushed late-night conversations or a solitary moment of respite. Like the Papoose sofa, presented in 2015, Algon's name references the North American Algonquian tribes.

Both frames of the armchairs are realized in moulded polyurethane foam. The internal cover can be improved by a quilt, that offers a pleasant welcome sensation; the seat cushion is made by shaped polyurethane foam with differentiated density. The seats stay lifted from the floor through the feet, in metal lacquered in the arflex collection or nickel-plated black.



Algon chair.

Algon chair, Rubycon cabinet.



Algon lounge chair.



Algon lounge chair, Capilano small table, Rubycon cabinet.



# >DIVA



Hug smaller side armchair, Ponti writing desk, Diva screen.

Claudine sofa, Ladle armchair, Diva screen, Tablet small table.

149 #arflex



# >VELA

design BERNHARDT&VELLA

Due vetri colorati con forme diverse, ma complementari, creano un gioco di trasparenze. Vela è un paravento che divide in maniera leggera e senza appesantire l'ambiente, creando giochi di ombre multicolore.

Two colored glasses with different shapes, but complementary, create a play of transparency. Vela is a screen that divides in a light and simple way, without weighing down the space, creating games of multicolored shadows.

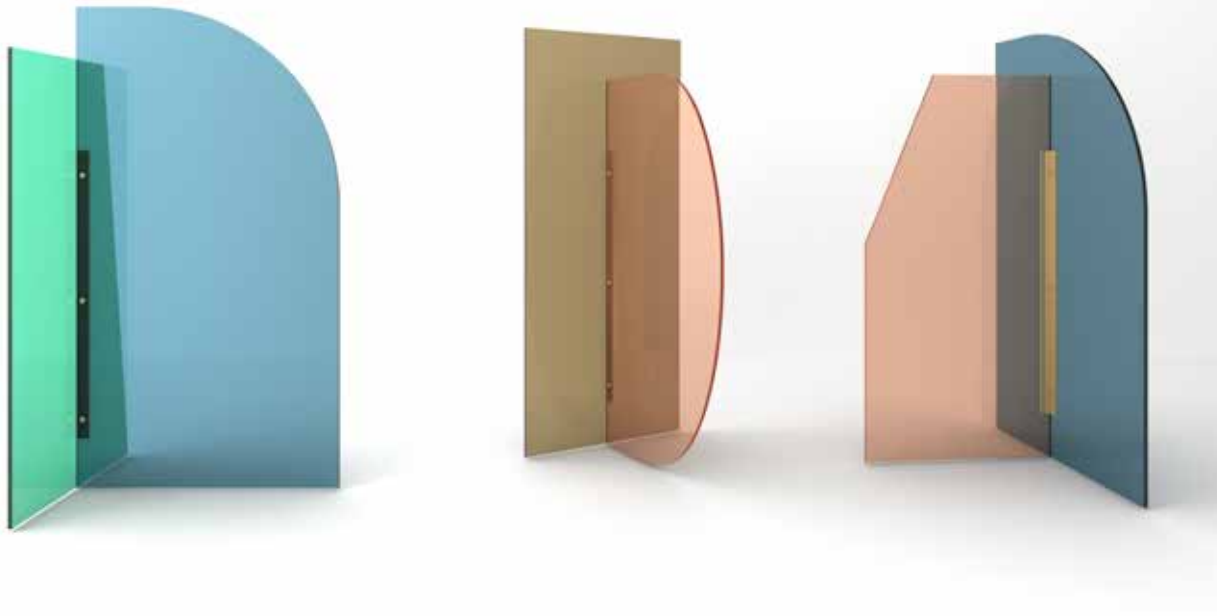

Vela screen.

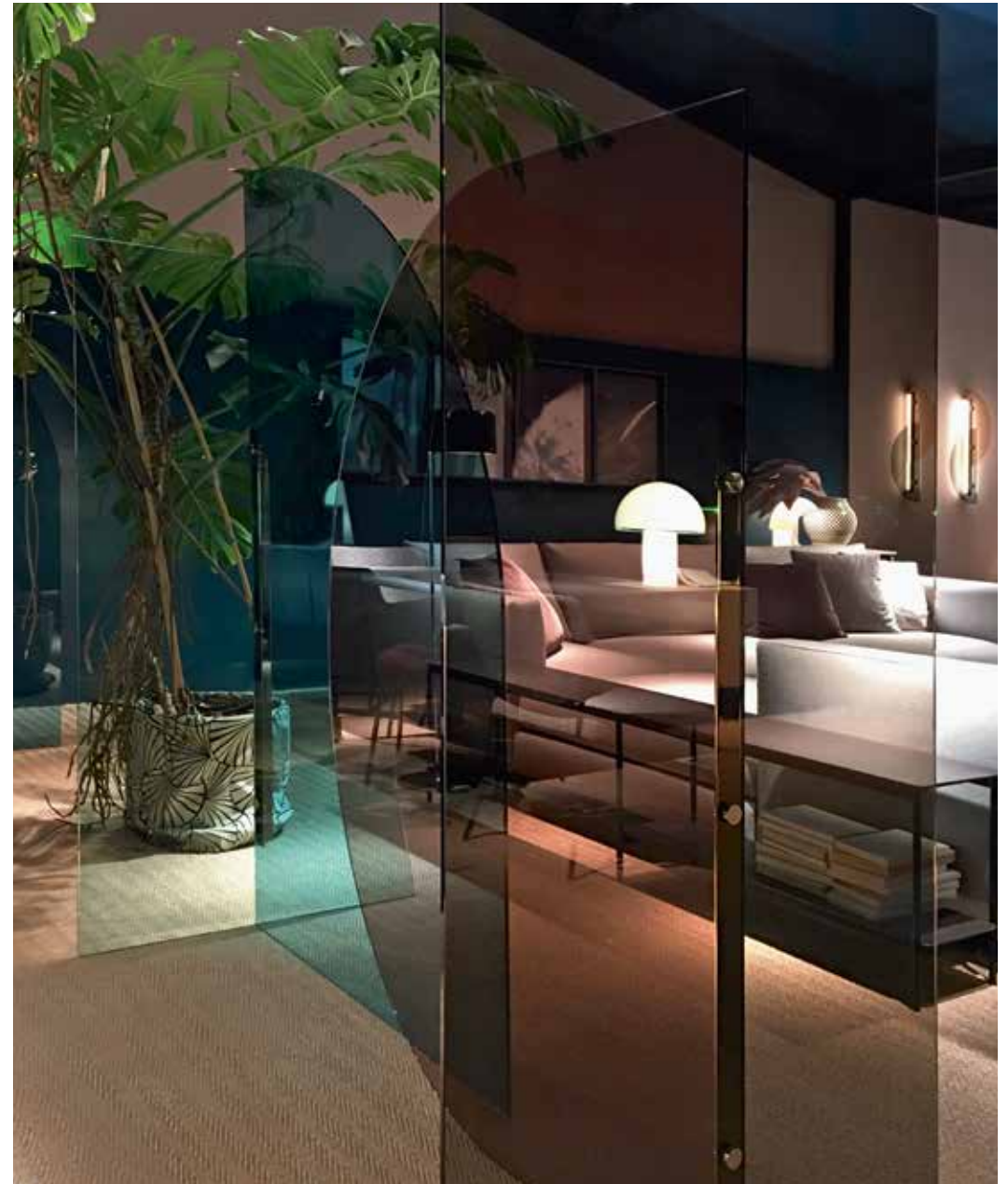



# > PAPILLON

design BERNHARDT&VELLA

La lampada applique Papillon gioca con trasparenze, colori e forme geometriche. I due strip LED sono integrati nell'asta centrale con finitura dorata, che fa da supporto ai due vetri colorati.

The applique lamp Papillon plays with transparencies, colors and geometric shapes. The two LED strips are integrated in the central beam with golden finishing, that supports the two colored glasses.

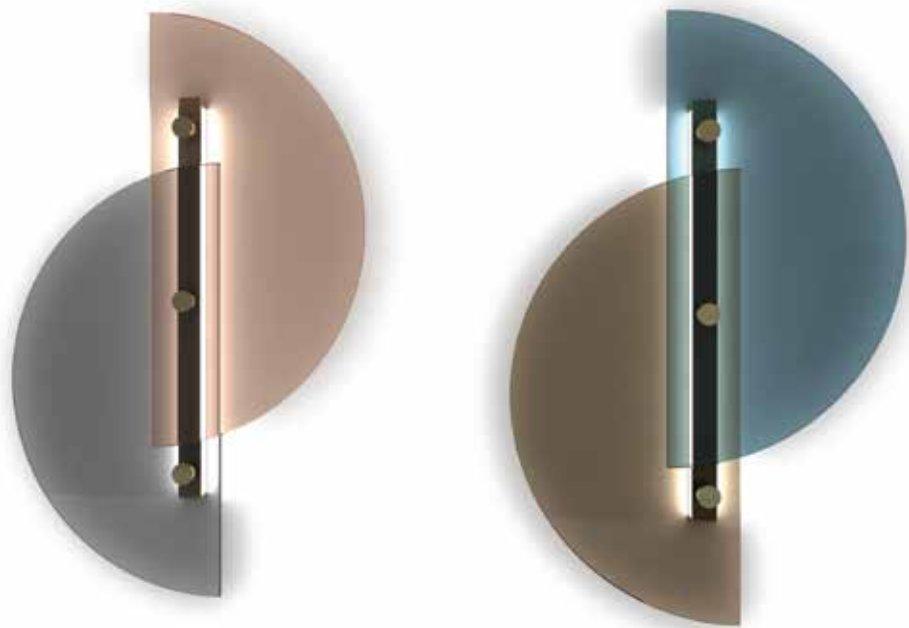

Papillon wall-lamp.



# > PONTI

design CLAESSION KOIVISTO RUNE



Ponti writing desk, Filù small table.



Cross armchair, Ponti writing desk.



# > LADLE

design LUCA NICHETTO

Il sistema di sedute Ladle si propone di riattualizzare in chiave contemporanea il design, ma soprattutto il feeling ed il comfort delle classiche sedute degli anni '60. Alla scocca di seduta, l'elemento costante nelle varie versioni, è possibile aggiungere tre diversi schienali, con altrettanti basi: quattro gambe in legno, quattro gambe in tubolare e a quattro razze girevole e oscillante. È possibile creare una grande varietà di proposte con un carattere personale pur mantenendo intatta la matrice estetica e funzionale, che si collocano individualmente all'interno di ambienti ed atmosfere molto diverse. I dettagli tessili, presenti in Ladle, danno particolare rilievo alla manualità ed alla lavorazione artigianale che caratterizza questo sistema di sedute.

The seat system Ladle wants to re-edit the design with a contemporary point of view, but above all the feeling and the comfort of the 60' years classic armchairs. The fixed element in the different versions is the seat frame, to which you can add three different backrests, with three different bases : four wooden legs, four tubular legs and four swivel and rocking spokes. It is possible to create a very large possibility of proposals with a personal character, maintaining the aesthetical and functional point of view. You can also use them individually in very different spaces and atmospheres. The fabric details, present in Ladle, give particularly importance to the handwork and manual skill, that will mark out this seat system.





Ladle armchair, Ladle pouf.

Ladle armchair.





Ladle armchair, Match consolle.



Ladle armchair, Match consolle.



# >MARECHIARO XIII



Marechiaro XIII sofa composition MH 05, Elettra armchair, Delfino pouf, Tablet small table.



Marechiaro XIII sofa composition MH 06, Hug armchair with high backrest,  
Tablet small table, Island small table.





Marechiaro XIII sofa composition MH 07, Penta pouf, Island small table, Tablet small table.



Marechiaro XIII sofa composition MH 04, armchair and pouf.



Marechiaro XIII sofa composition MH 08, Hug armchair with high backrest, Hug small table.





>K2  
design CARLO COLOMBO







# > COUSY

design VINCENT VAN DUYSSEN



Cousy armchair.

175 #arflex





Cousy sofa, Octopus small table.



# > FRAME

design CARLO COLOMBO

Il sistema di seduta Frame ha una linea confortevole; la sua struttura può essere arricchita dall'intreccio manuale del cuoio, per dare al divano una scenografia elegante.

The seating system Frame has a comfortable line; its structure can be enriched by the manual interlacement of the cowhide, for giving to the sofa an elegant scene.



Frame sofa composition F3.





Frame sofa composition F9, Serena armchair, Match bookcase, Tablet small table.

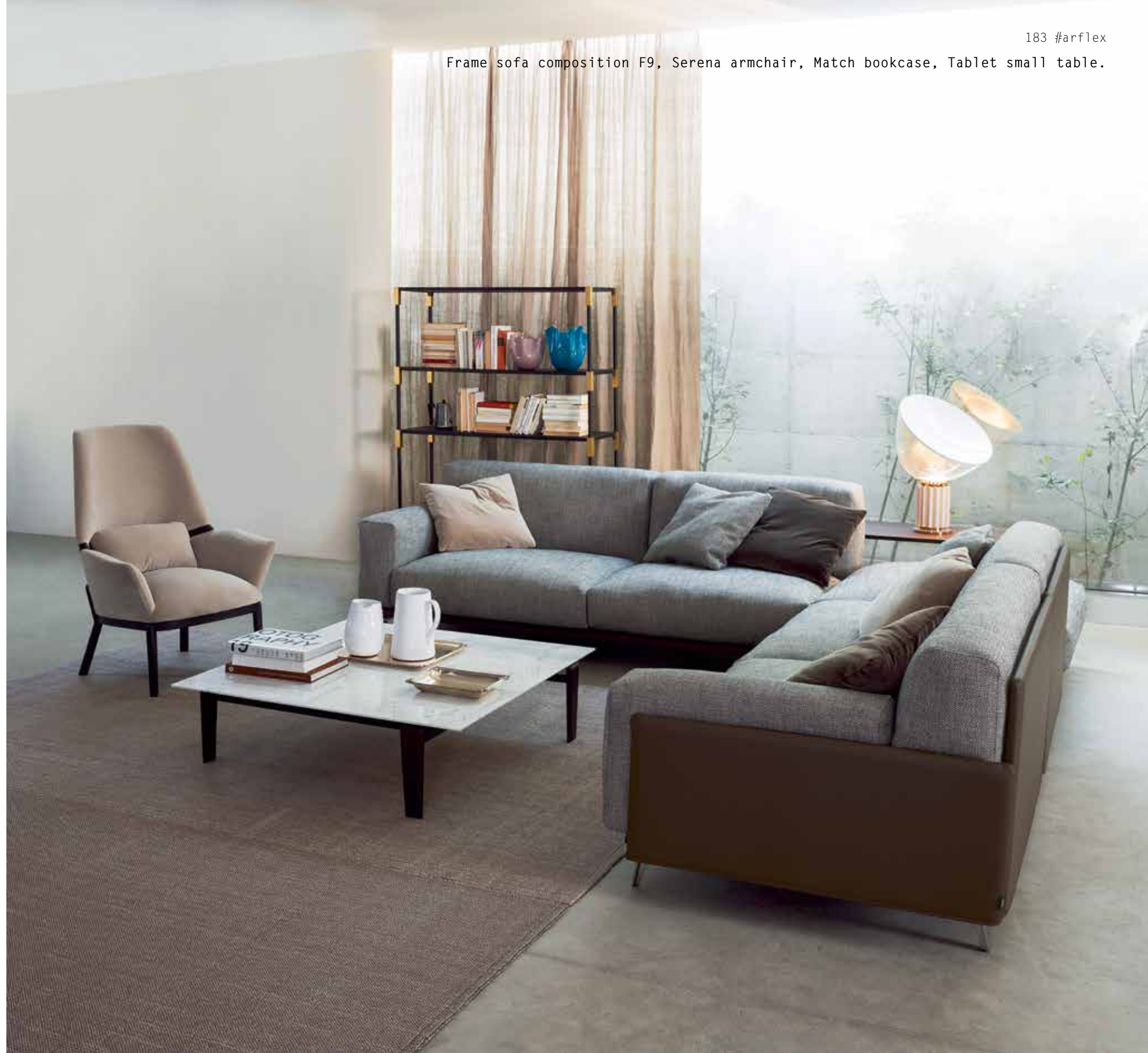





Frame sofa, Marengo armchair, Tablet small table.



Frame sofa composition F6.





Faubourg sofa.





# > SERENA & DOGE

design LUCA NICHETTO





Serena armchair, Doge pouf.





# > FIORENZA

design FRANCO ALBINI

Fiorenza armchair, Cocca armchair, Octopus small table.



# > COCCA

design CARLO COLOMBO



# > TABLET

design CLAESSION KOIVISTO RUNE





# > HOLLY - WOOD

design CLAEISSON KOIVISTO RUNE

Holly wood sofa composition H 03, Gina armchair.



# > HOLLYWOOD

design CLAEISSON KOIVISTO RUNE



Hollywood sofa composition H 08, Hollywood pouf, Tablet small table.



Hollywood sofa composition H12, Jules armchair, Match bookcase, Tablet small table, Filu' small table.

205 #arflex



Hollywood sofa composition H12, Match bookcase, Tablet small table, Filu' small table.

207 #arflex





Hollywood sofa composition H 07, Hollywood pouf, Hillside furniture unit, floor version.

209 #arflex



# > CLAUDINE

design CLAESSION KOIVISTO RUNE

Una tipologia classica servita su un vassoio delicato. Il divano è flessibile nella configurazione - alto, basso, piccolo, grande, 2 sedute, 3 sedute, poltroncina. Sempre basato su un bordo capovolto, che ricorda il colletto dei vestiti conosciuto in Francia con il nome di "col Claudine".

A classic typology served on a tender tray. The sofa is flexible in configuration - high, low, narrow, wide, two-seater, three-seater, easy chair. Always floating on an upturned edge, reminiscent of the dress collar known in French as the "col Claudine".



Claudine sofa, Tablet small table, Diva screen.

211 #arflex





Claudine sofa composition CLL 01, Delfino armchair, Tablet small table, Filù small table.

213 #arflex

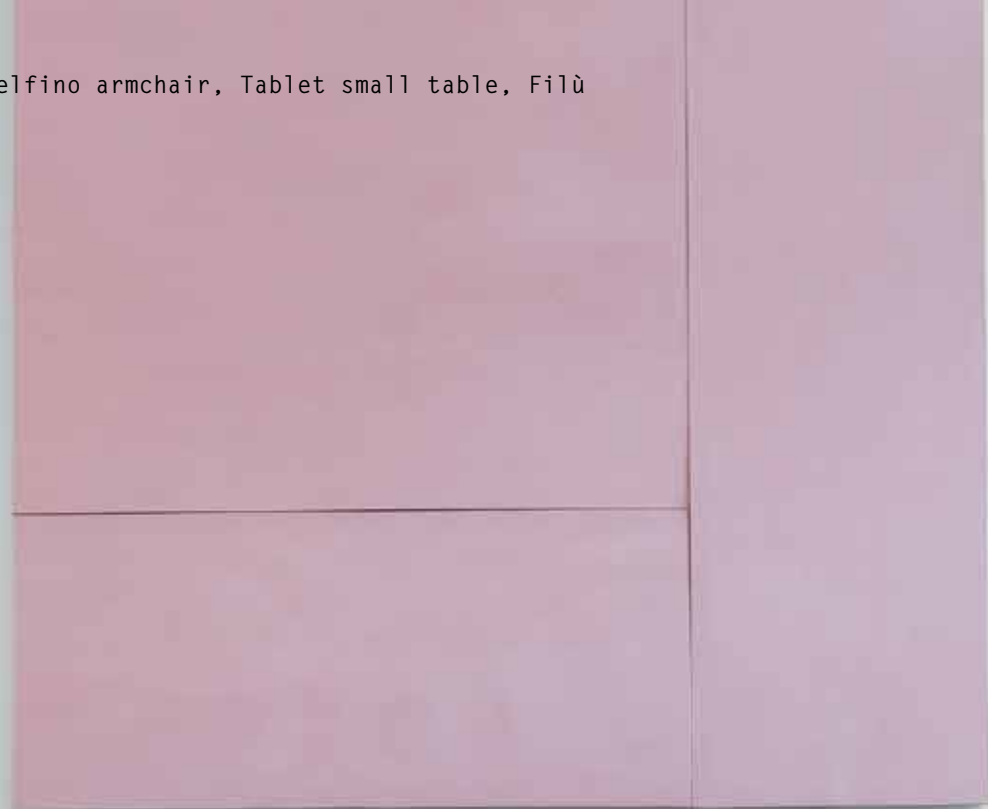





Claudine sofa composition CLM 04, Hug love seat sofa, Botolo armchair, Island small table, Tablet small table, Diva screen.



# >SOFT BEAT

design CLAEISSON KOIVISTO RUNE

Flutti calmi, colline ondeggianti, energia rassicurante:  
bello, morbido, da icona - soft beat (battito delicato).  
Slow waves. Rolling hills. Soothing pulse. Kind. Soft.  
Iconic - Soft Beat



Soft Beat sofa composition SB 03.



Soft Beat sofa composition SB 01, Elettra armchair, Match small table.



>GINA  
design PAOLA VELLA



Gina armchair, Filù small table.

# > CANDY

design CARLO COLOMBO

Candy sofa, Tablet small table, Diva screen.





Candy sofa, Pecorelle armchair, Island small table, Diva screen.





# >PENTA

design CLAEISSON KOIVISTO RUNE

I mobili di design normalmente richiedono una scelta tra l'impercettibile e il caratteristico. Ma se si vogliono entrambe? La nostra soluzione a questo dilemma deriva dalla nostra ricerca architettonica: abbiamo trovato che il pentagono è la forma migliore per combinare una certa integrità geometrica senza doversi adattare all'ordine circostante. In altre parole: ha una forma distinta.

Furniture design normally requires a choice between subtle and characteristic. But what if you want both? Our solution to this comes from our own architectural research: we have found that the pentagon is the best shape to combine a certain geometrical integrity without having to adapt to the surrounding order. In other words: It has a distinct shape.

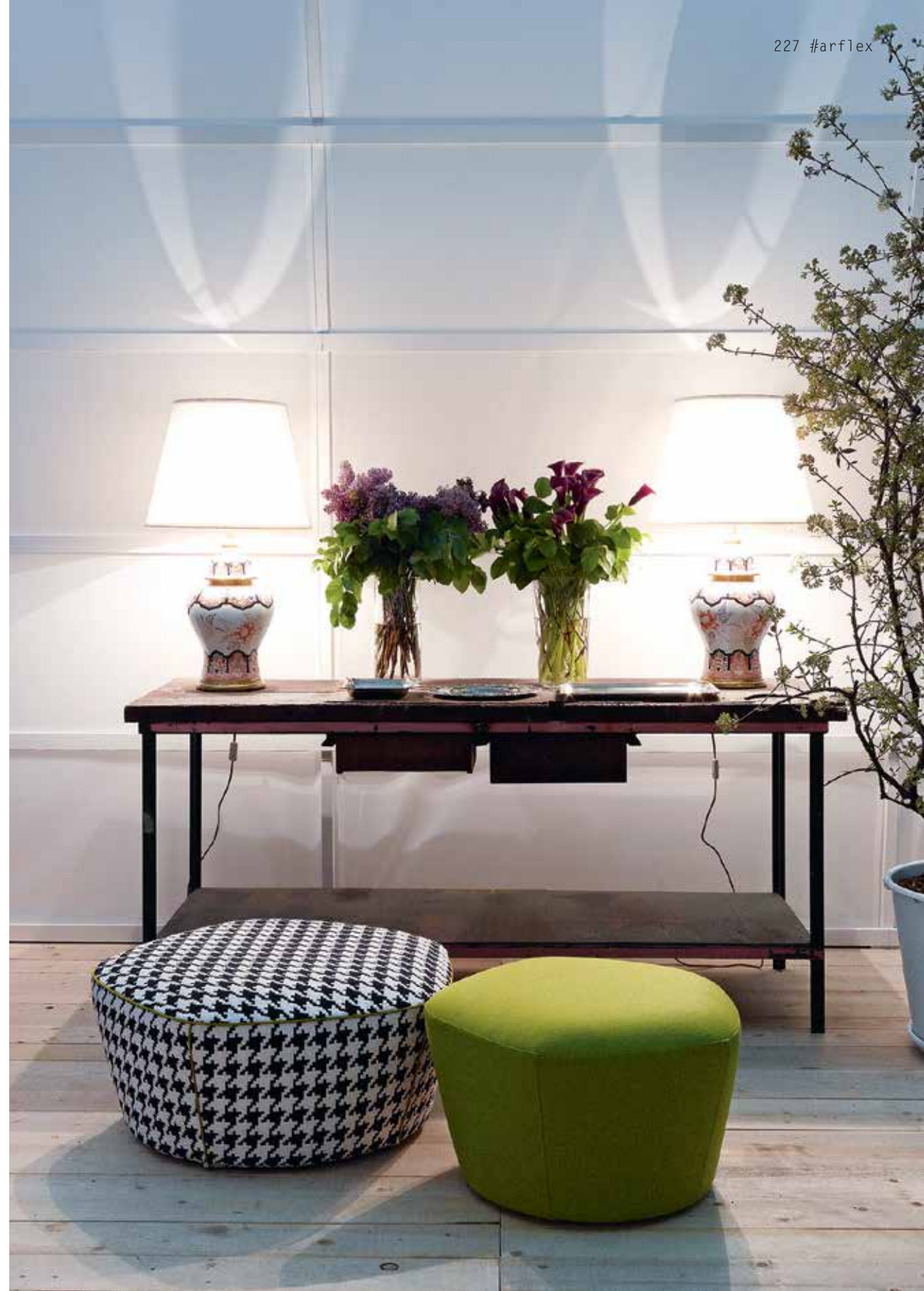



# > DANDY

Dandy sofa, Filù small table.



> FILU'  
design PAOLA VELLA



Filù small table and bookcase.





# > NAVIGLIO

design UMBERTO ASNAGO



Naviglio sofa, Filù bookcase.







Naviglio sofa.



Naviglio sofa composition.





Charles sofa, Gina armchair, Filù small table.

> TABOGA  
design CINI BOERI



Hollywood sofa, Taboga armchair, Tablet small table.



# > ITACA



Itaca sofa composition I03, Marengo armchair.

# > SENNA



Senna sofa composition SE08, Elettra armchair, Pouf.



> ISLAND  
design BERNHARDT&VELLA



Island small table, Diva screen.





Sella armchair.



>LIPS  
design CARLO COLOMBO



# > ARMILLA

design BURKHART VOGTHERR



# > MOJO

design CLAEISSON KOIVISTO RUNE





# >OCTOPUS

design CARLO COLOMBO



Strips sofa, Octopus small table, Hillside furniture unit, air version.

# >BUTTERFLY

design MAURO LIPPARINI

Butterfly armchair, Filù bookcase.



# > KATRIN

design CARLO COLOMBO

# > VIRGOLA

design YAACOV KAUFMAN





# > FELIX

design BURKHARD VOGTHERR



Felix sofa and armchair, Tablet small table.

261 #arflex



# >CLOUD COLLECTION

design CARLO COLOMBO

Cloud collection, sviluppata per trovare uno stile di vita più in sintonia con la natura e con la solarità visiva con forme morbide e accoglienti.

Cloud collection, worked out to find a lifestyle nearer to nature and to a visual luminosity, with soft and cosy shapes.





# > PALAZZO

design BERNHARDT&VELLA

Palazzo bed, Elettra armchair, Island small table.



# >SUITE

design BERNHARDT&VELLA



Suite bed, Fiorenza armchair, Filù small table, Tablet small table.



# >JOY

design CLAESSION KOIVISTO RUNE

Il letto Joy è luminoso e lineare, galleggiante e grafico, con la sua caratteristica nelle morbide progressive curve dell'imbottitura della testata, allo stesso tempo maschile e femminile.

The bed Joy is light and linear. Floating and graphic with its feature in the soft progressive curves of the backrest padding, at once masculine and feminine.





Joy bed, Boborelax armchair, Pouf, Tablet small table, Ponti writing desk.

271 #anflex

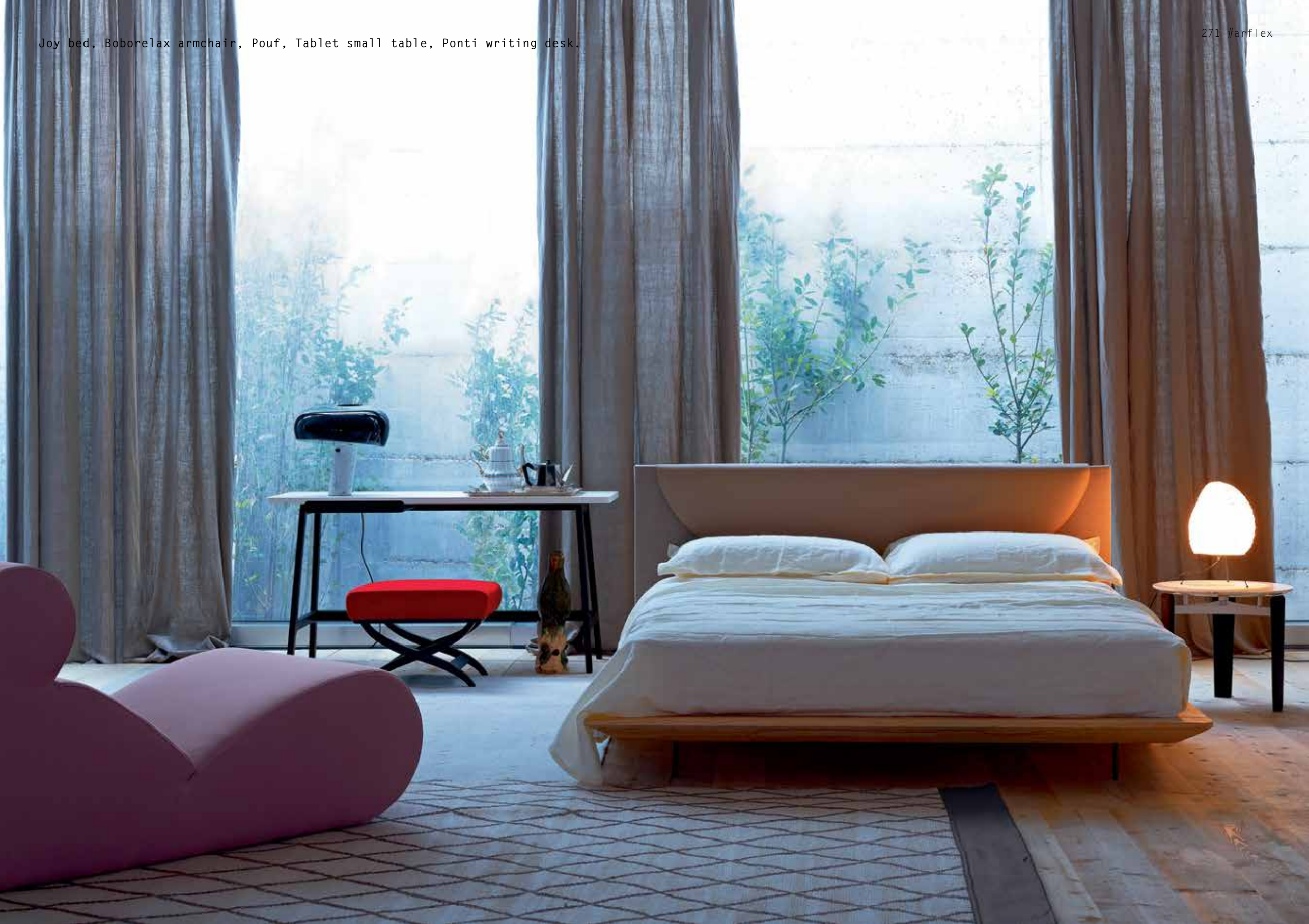



# > LEDLETTO

design CINI BOERI

Ledletto bed, Ladle armchair, Ponti writing desk.

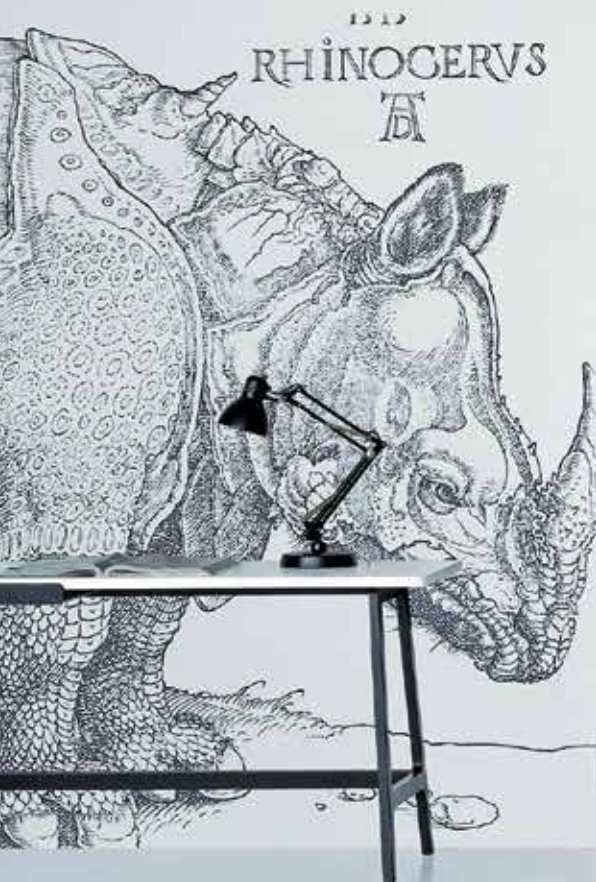

> DISEGNI TECNICI  
TECHNICAL DRAWINGS



**DIVANI\_SOFAS**

**BEN BEN Divano\_Sofa**



divani sofas

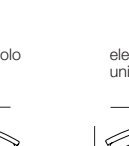
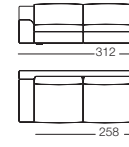
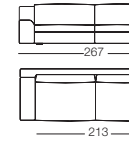
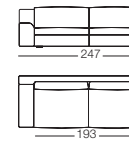
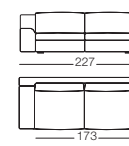
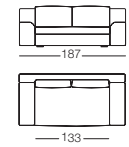
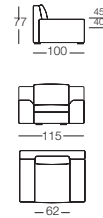

elementi con 1 bracciolo units with 1 armrest

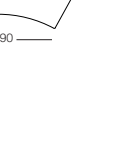
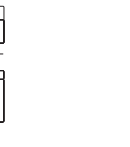
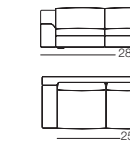
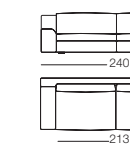
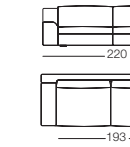
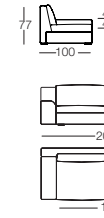

elementi angolo con 1 bracciolo corner units with 1 armrest

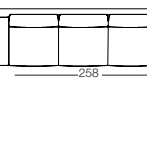
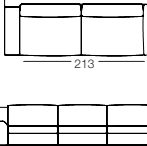
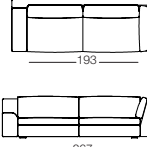
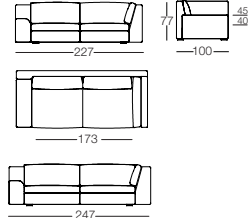

elementi isola con angolo isle units with corner unit

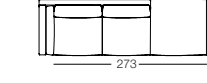
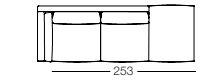
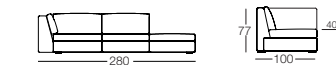

pouf

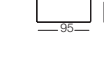
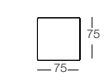

elementi curvi curved units

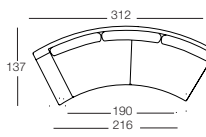
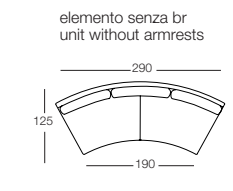
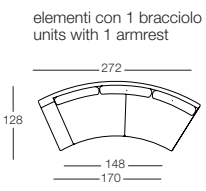
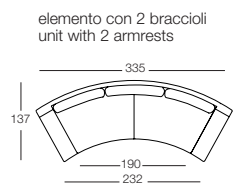

elemento con 2 braccioli unit with 2 armrests

elementi con 1 bracciolo units with 1 armrest

elemento senza br unit without armrests

**BOBO Divano\_Sofa**



divano sofa

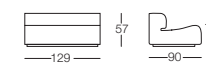

**BONSAI Divano\_Sofa**



divano / base in legno sofa / wooden base

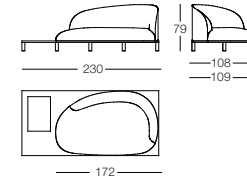

divano / base in legno con lampada sofa / wooden base with lamp

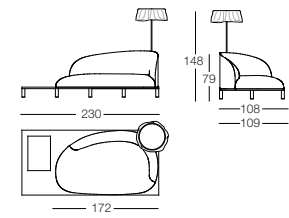

pouf / base in legno sofa / wooden base

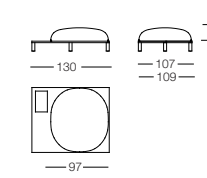

divano / base in metallo sofa / metal base

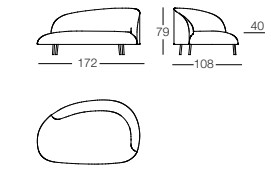

pouf / base in metallo sofa / metal base

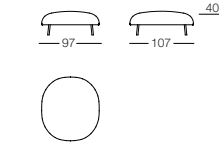

tavolino small table

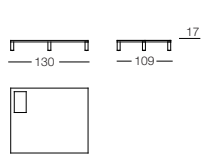

**CHARLES Divano\_Sofa**



divani sofas

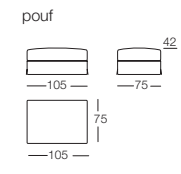
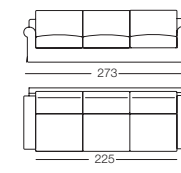
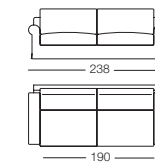
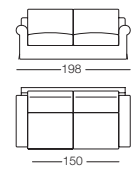
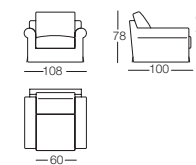

**CANDY Divano\_Sofa**



divani sofas

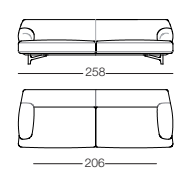
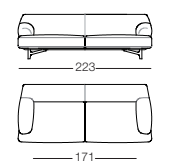
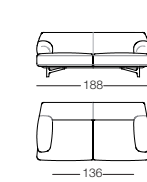
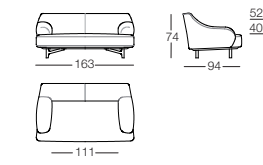



elementi con 1 bracciolo  
units with 1 armrest

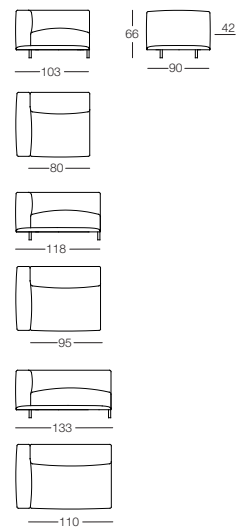

elementi senza braccioli  
units without armrests

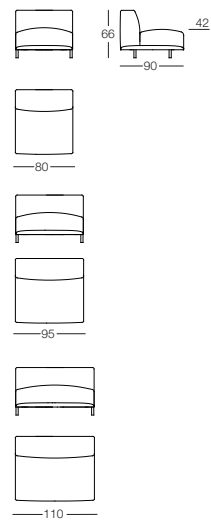

elemento angolo  
corner unit

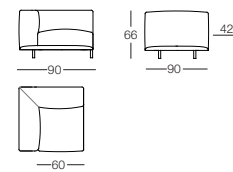

chaise longue con 1 bracciolo  
chaise longue with 1 armrest

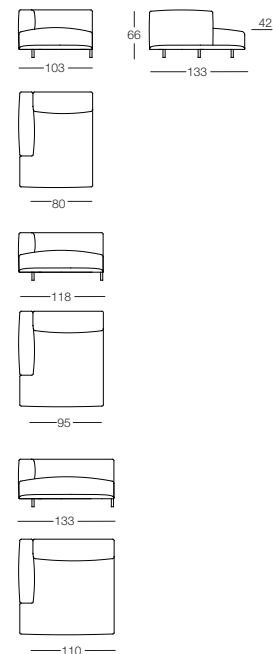

pouf

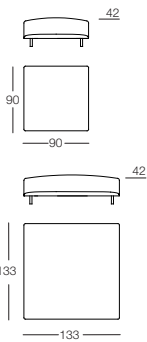

COMPOSIZIONI **M / L**  
COMPOSITIONS **M / L**

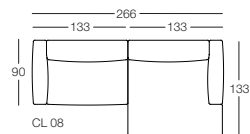
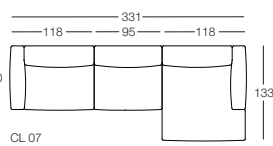
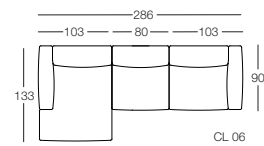
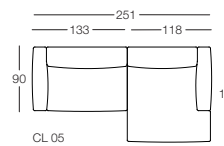
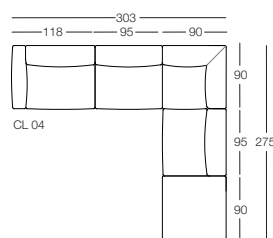
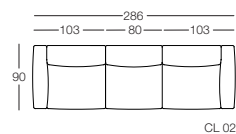
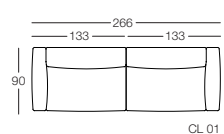

elementi con 1 bracciolo  
units with 1 armrest

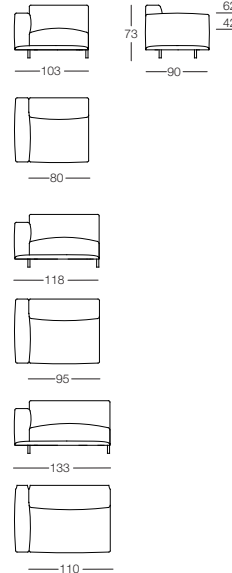

elementi senza braccioli  
units without armrests

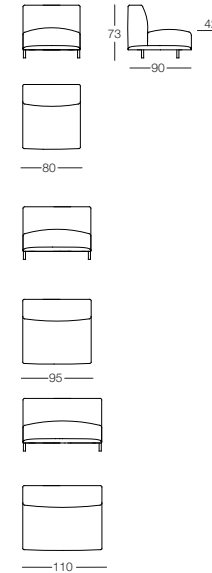

elemento angolo  
corner unit

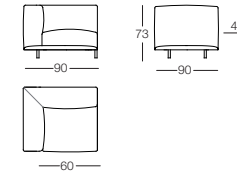

chaise longue con 1 bracciolo  
chaise longue with 1 armrest

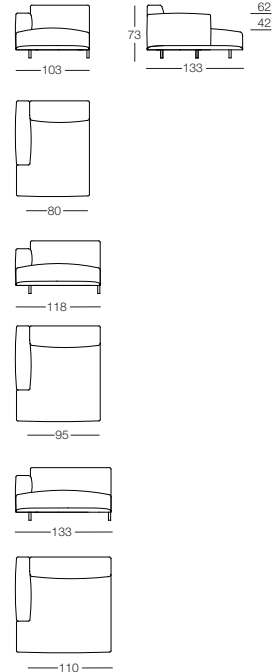

pouf

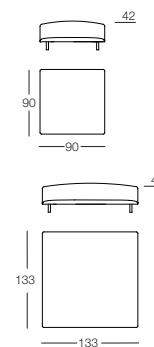



COUSY Divano\_Sofa



divani  
sofas

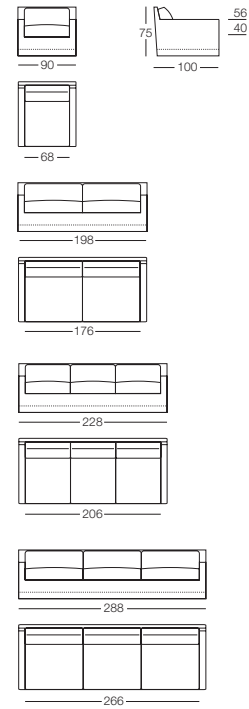

chaise longue

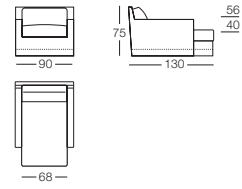

pouf

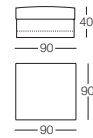

DANDY Divano\_Sofa



divani  
sofas

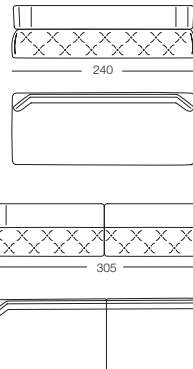
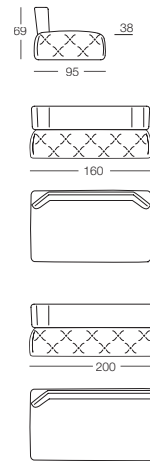

FAUBOURG Divano\_Sofa



divani  
sofas

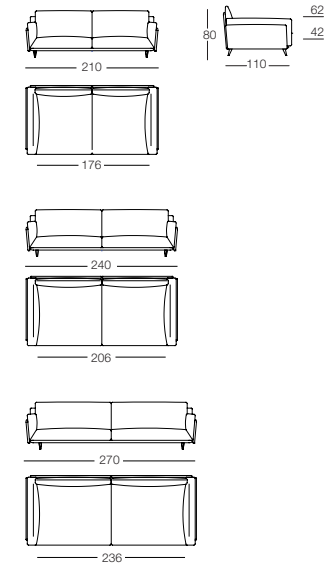

cuscini arredo  
loose cushions

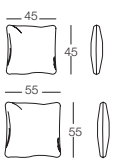

FELIX Divano\_Sofa



poltrona  
armchair

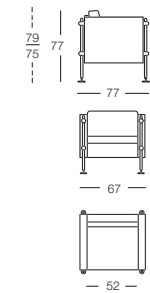

accessori  
accessories

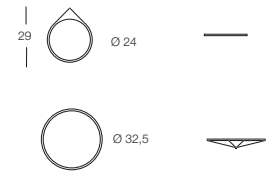

divani  
sofas

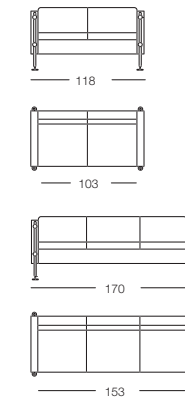



divani  
sofas

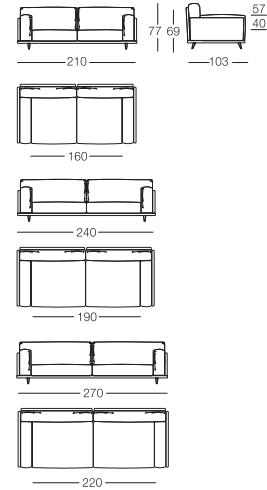

elementi con 1 bracciolo  
units with 1 armrest

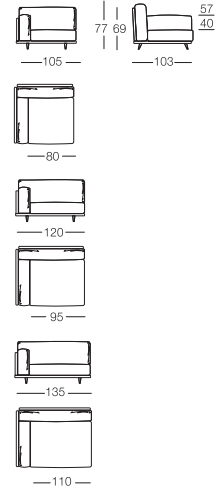

elementi senza braccioli  
units without armrests

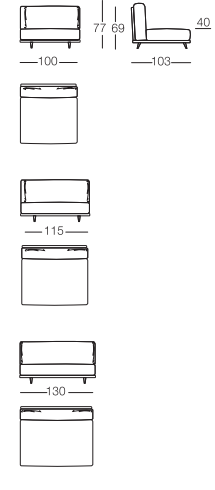

elementi angolo  
corner units

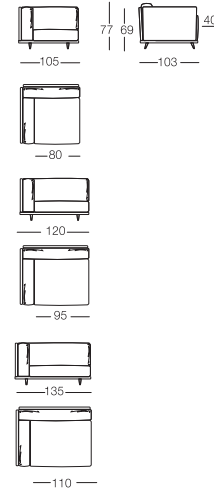

chaise longue  
chaise longue

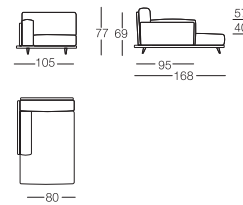

pouf

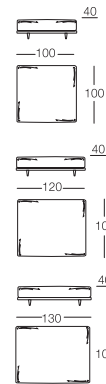

elementi in cuoio intrecciato  
units in interwoven cow-hide

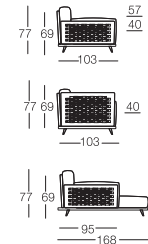

COMPOSIZIONI  
COMPOSITIONS

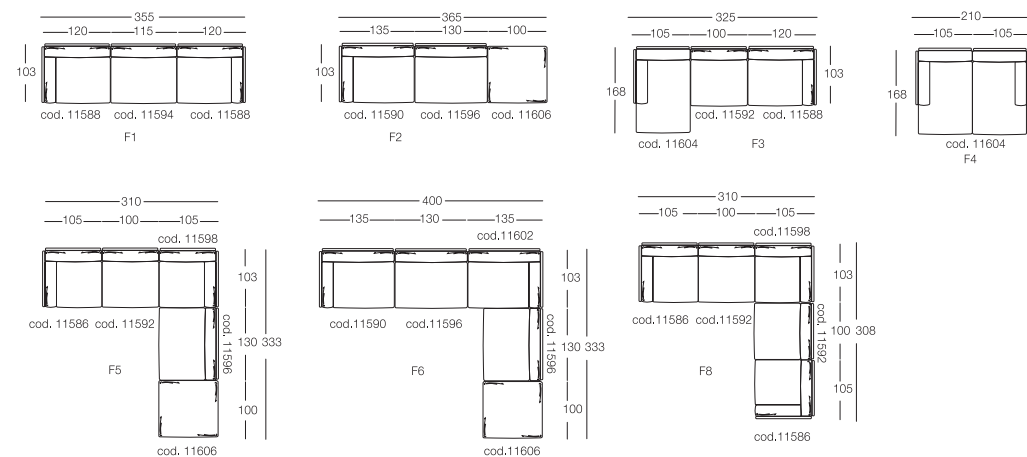

divani con braccioli larghi /  
divani angolo con 1 bracciolo  
Sofas with large armrests /  
corner sofas with 1 armrest

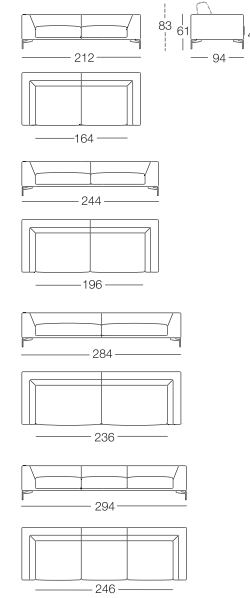

Pouf

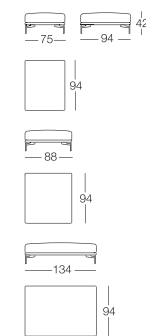

elementi con 1 bracciolo largo /  
elementi angolo  
units with 1 large armrest /  
corner units

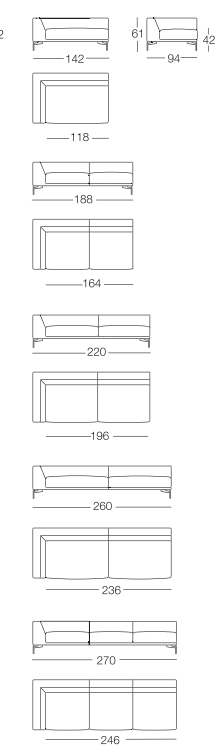

Cuscini schienale  
Backrest cushions

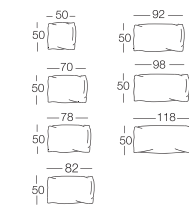

Cuscino angolo  
Corner cushion



Chaise longue con bracciolo largo  
Chaise longue with large armrest

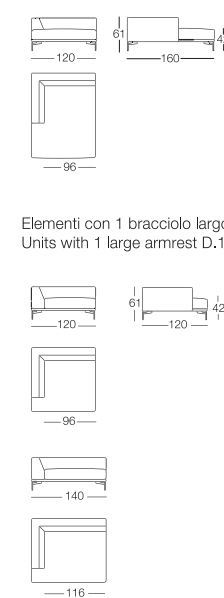

Elementi con 1 bracciolo largo P.120  
Units with 1 large armrest D.120

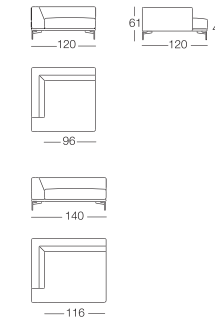

Elementi senza braccioli  
Units without armrests

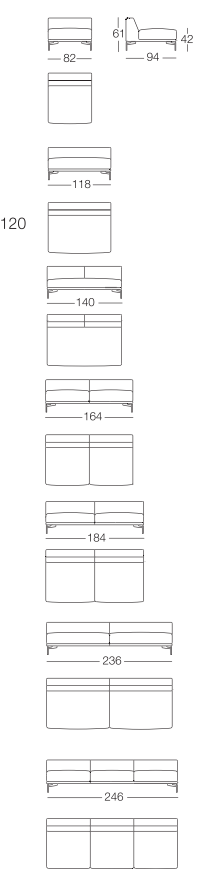

Elemento senza braccioli P.120  
Unit without armrests D.120

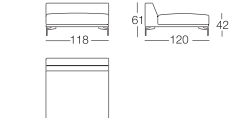

Elementi isola senza bracciolo  
Isle units without armrest

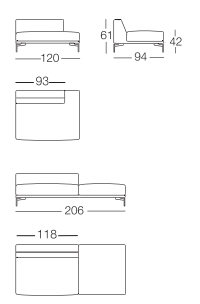

Elementi isola con angolo  
Isle units with corner unit

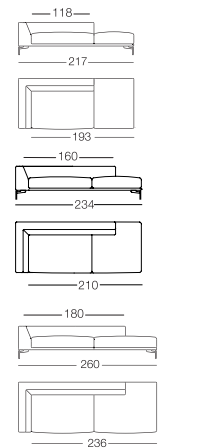





ITACA Divano\_Sofa



elementi angolo senza bracciolo  
corner units without armrest

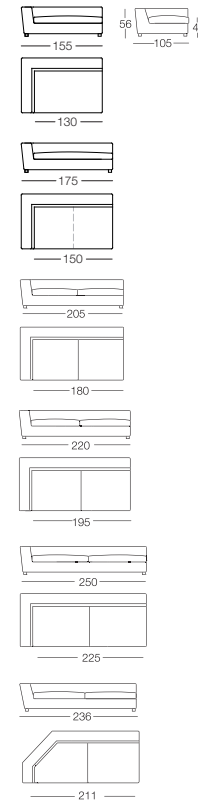

chaise longue

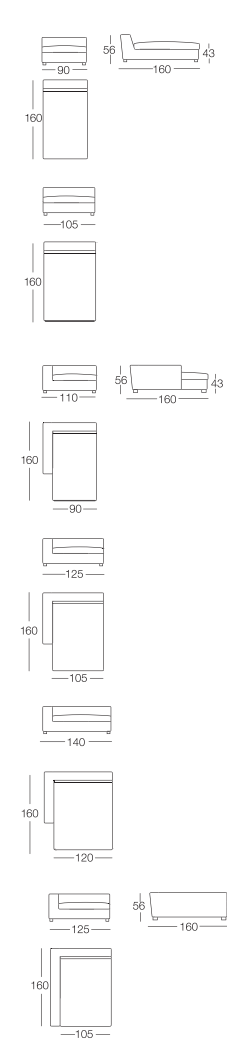

pouf

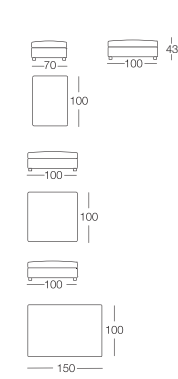

cuscini schienale  
backrest cushions

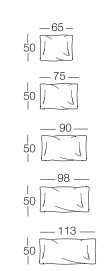

cuscino schienale con rullo  
backrest cushion with roll cushion



divani  
sofas

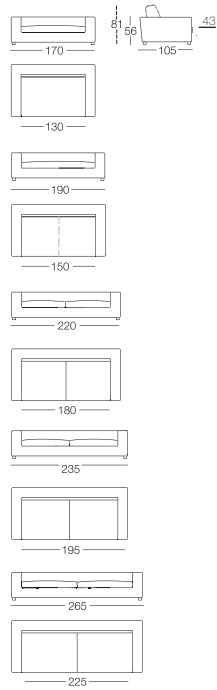

elementi con 1 bracciolo  
units with 1 armrest

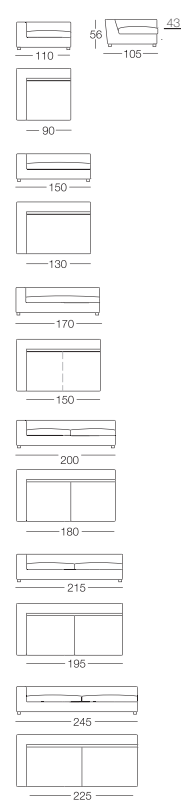

elementi senza braccioli  
units without armrests

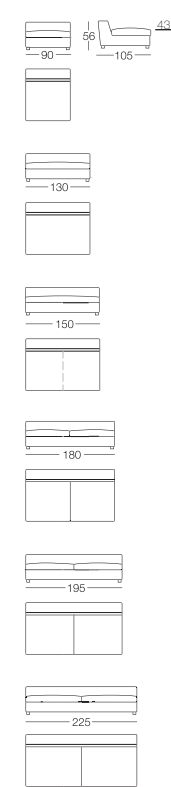

elementi angolo con 1 bracciolo  
corner units with 1 armrest

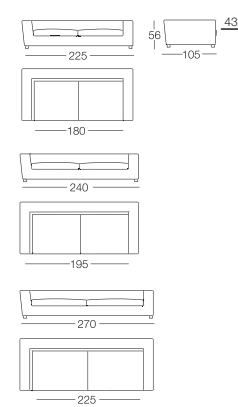

elementi angolo con isola  
corner units with isle

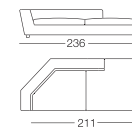

COMPOSIZIONI  
COMPOSITIONS

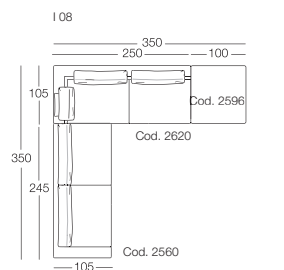
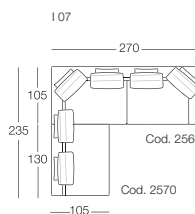
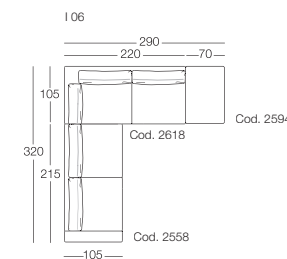
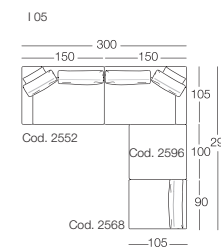
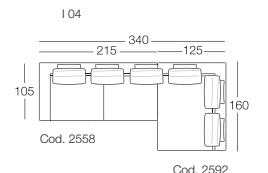
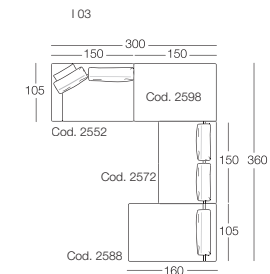
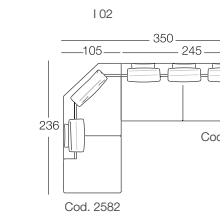
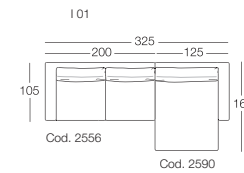





divani versione alto  
sofas high version

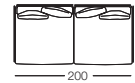
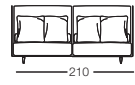
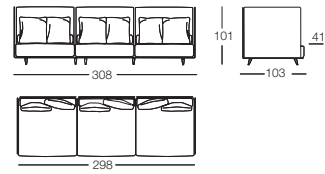

divani versione basso  
sofas low version

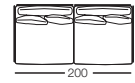
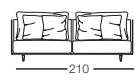
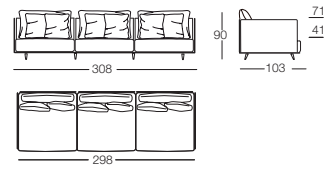

elementi con 1 bracciolo  
units with 1 armrest

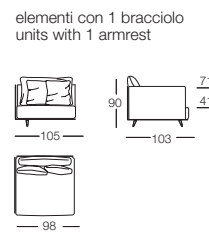
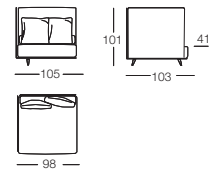

pouf

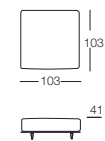

elementi senza braccioli  
units without armrests

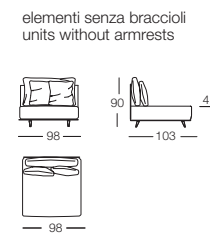
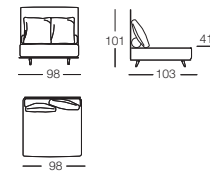

cuscini  
cushions

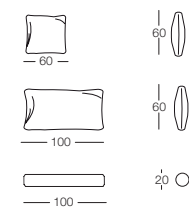

elementi angolo  
corner units

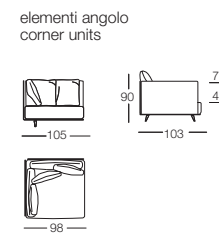
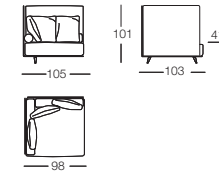

poltrona  
armchair

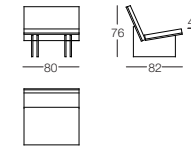

divani  
sofas

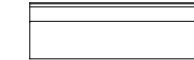
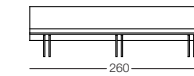
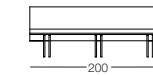
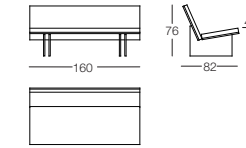

divano con schienale alto  
sofa with high backrest

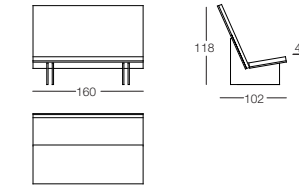

chaise longue  
chaise longue

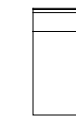

trapunta  
cover

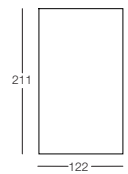



COMPOSIZIONI  
COMPOSITIONS

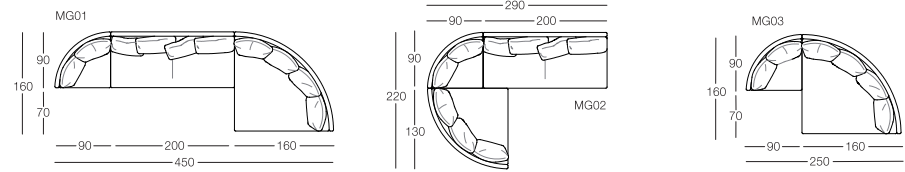

Mangold **L**

elementi senza braccioli  
units without armrests

elementi curvi senza braccioli  
curved units without armrests

Mangold **H**

elementi senza braccioli  
con schienale alto  
units without armrests  
with high backrest

elementi curvi senza braccioli  
con schienale alto  
curved units without armrests  
with high backrest

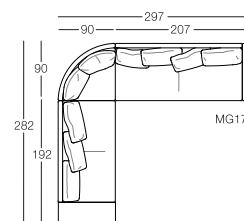
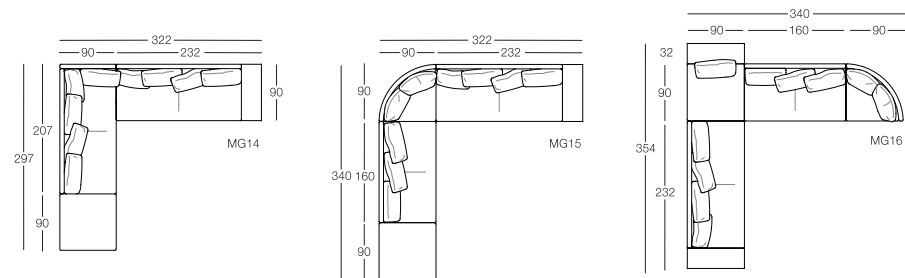
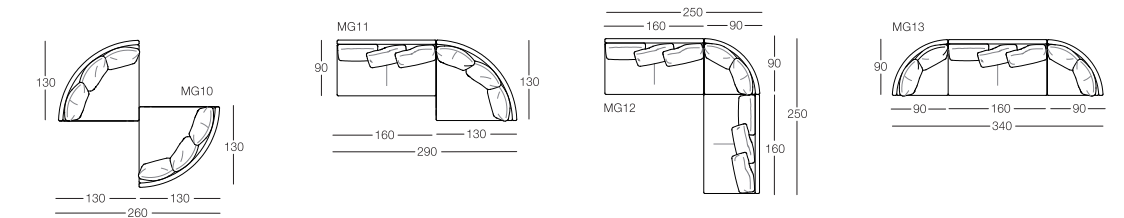
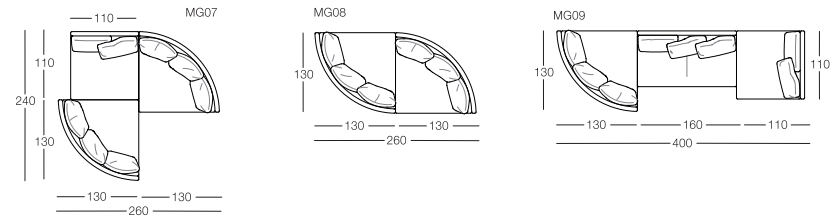
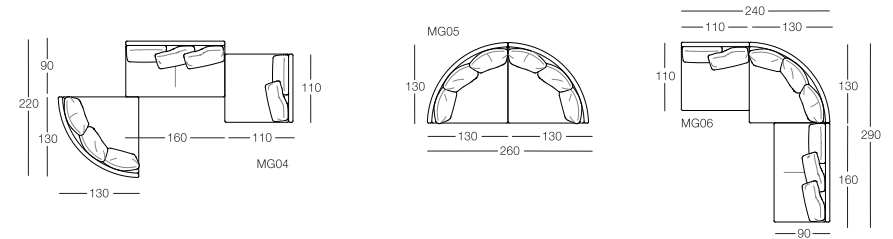
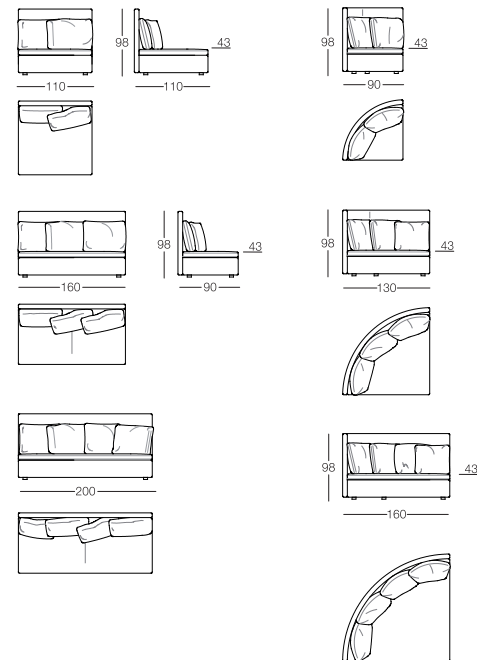
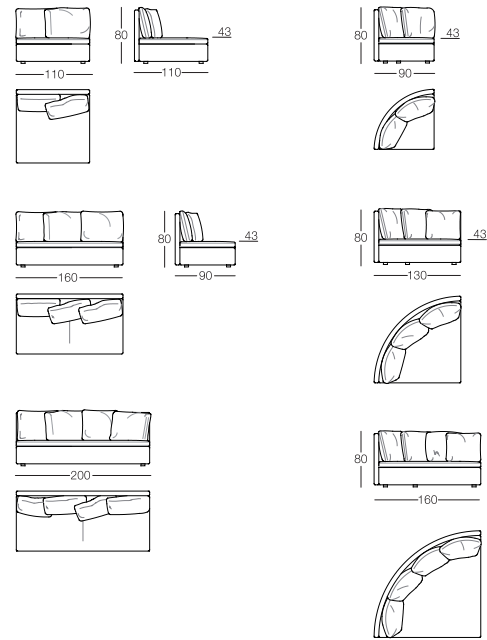

pouf

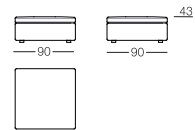

bracciolo angolo basso  
low corner armrest

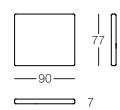

bracciolo angolo alto  
high corner armrest

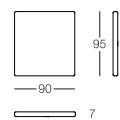

bracciolo mobiletto  
furniture armrest

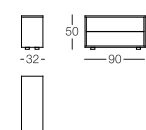

tavolino  
small table

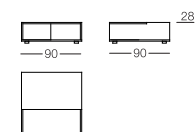

cuscini  
cushions

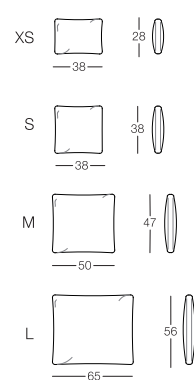





poltrone  
armchairs

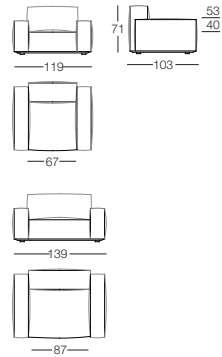

elementi 1 bracciolo  
units with 1 armrest

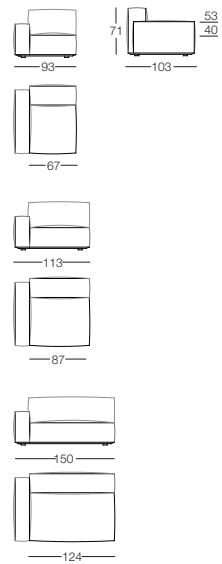

poltrone con braccioli alti  
armchairs with high armrests

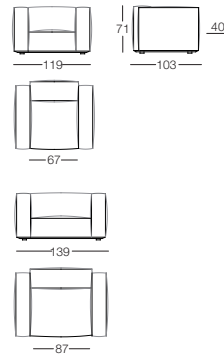

elementi 1 bracciolo alto  
units with 1 high armrest

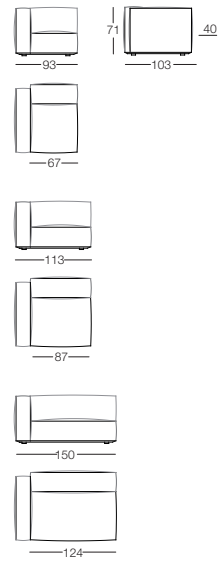

elementi senza braccioli  
units without armrests

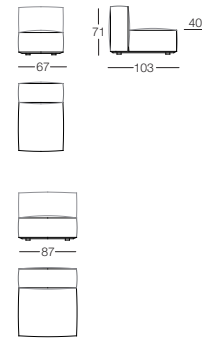

elementi angolo  
corner units

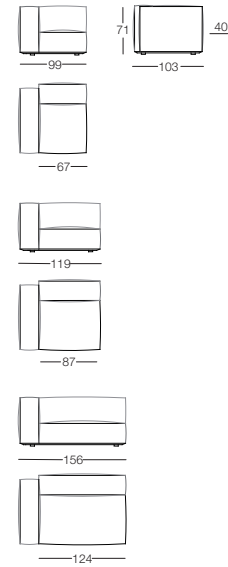

elementi 1 bracciolo P. 124  
units with 1 armrest D. 124

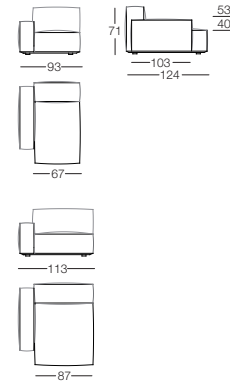

elementi 1 bracciolo lungo P. 124  
units with 1 long armrest D. 124

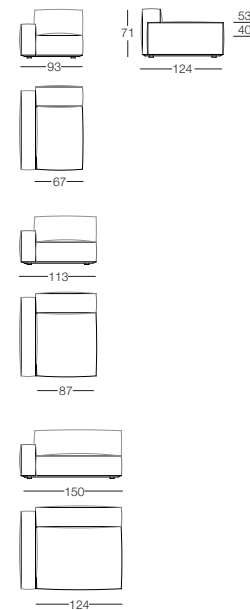

elementi senza braccioli P.124  
units without armrests D. 124

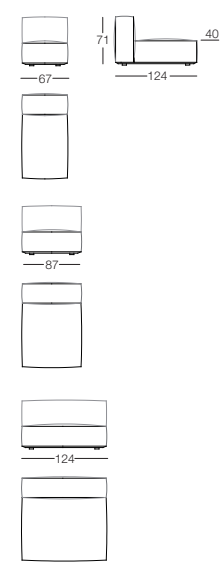

elementi angolo P.124  
corner units D.124

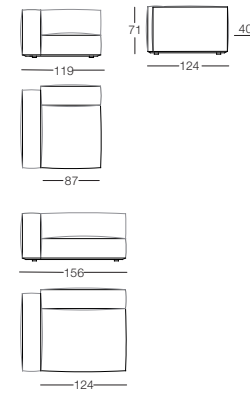

pouf

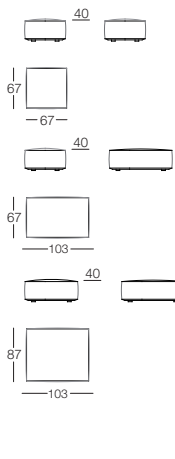

chaise longue

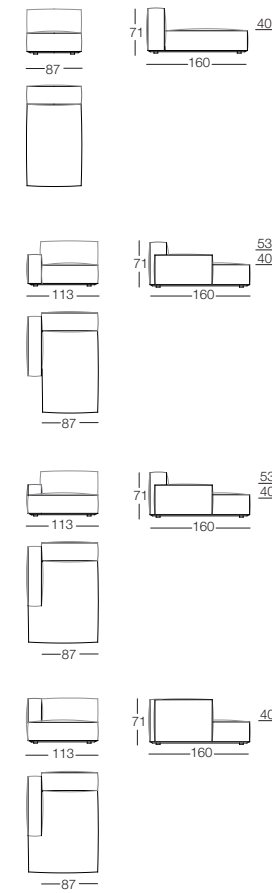

elementi isola  
isle units

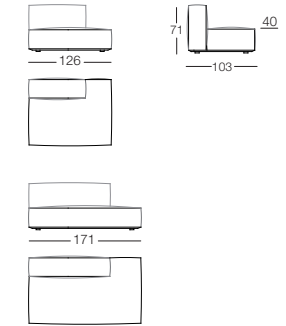

elementi curvi  
curved units

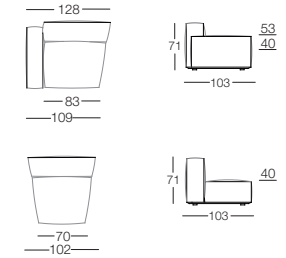

COMPOSIZIONI  
COMPOSITIONS

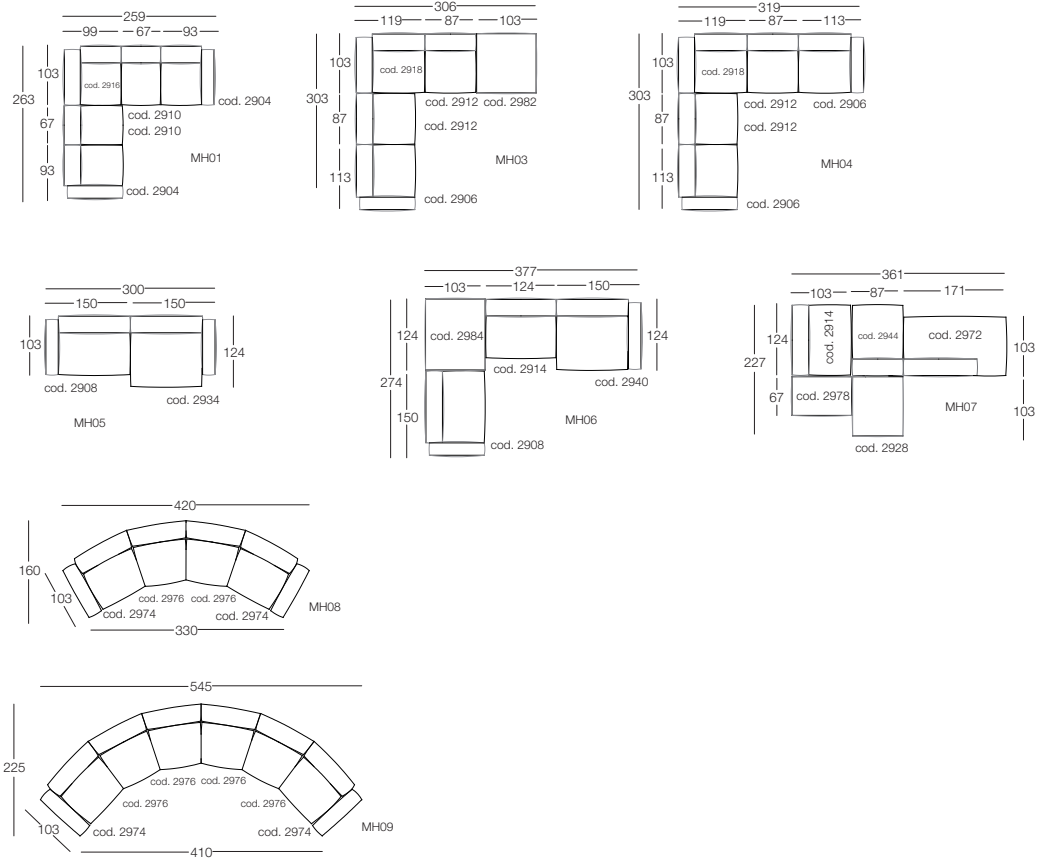

MARENCO Divano\_Sofa

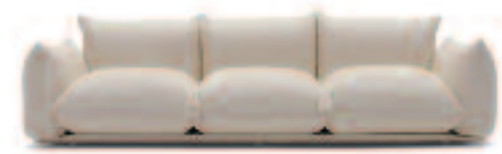

divani  
sofas

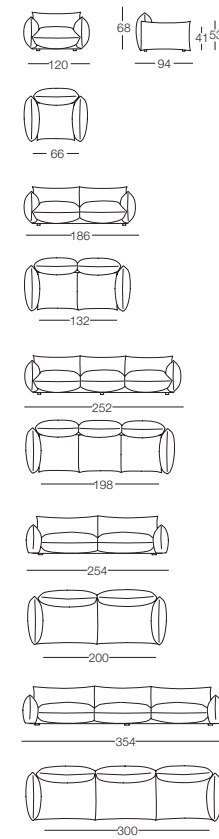

elementi 1 bracciolo  
units with 1 armrest

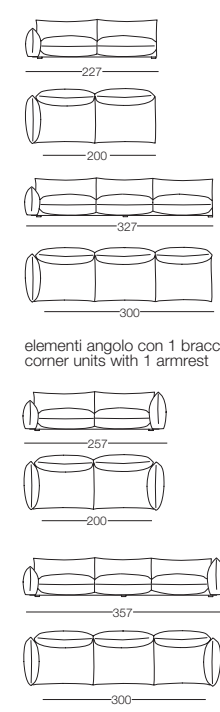

elemento isola con angolo  
isle unit with corner unit

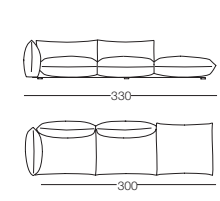

elemento isola  
isle unit

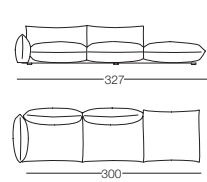

pouf

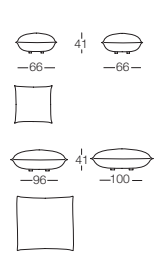

COMPOSIZIONI  
COMPOSITIONS

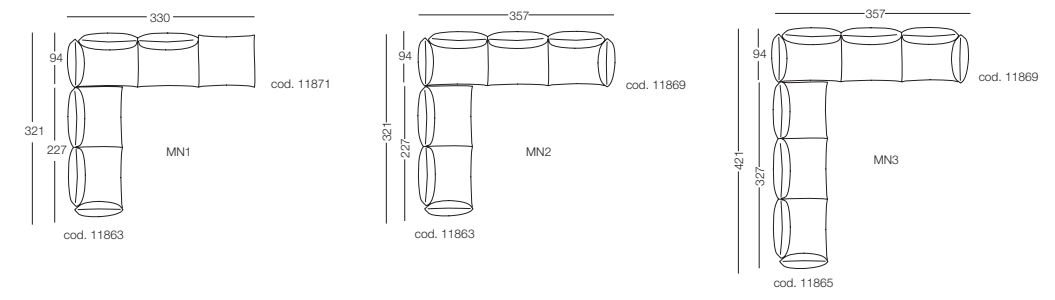





divani  
sofas

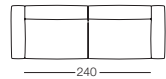
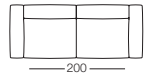
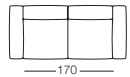

elementi con 1 bracciolo  
units with 1 armrest

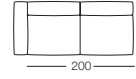
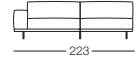
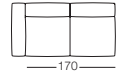

elementi angolo con 1 bracciolo  
corner units with 1 armrest

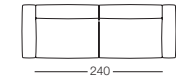
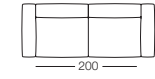
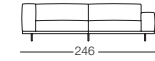
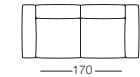
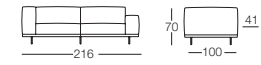

pouf

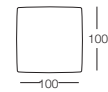

divani 174  
sofas 174

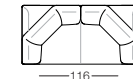
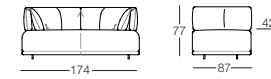
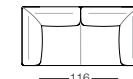
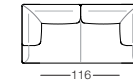

divani 261  
sofas 261

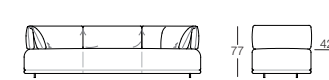
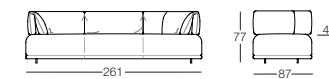
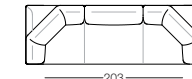
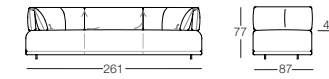
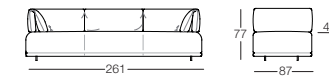
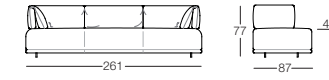

elemento con 1 bracciolo 174  
unit with 1 armrest 174

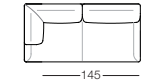
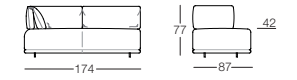

elementi angolo 174  
corner units 174

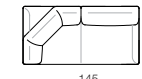
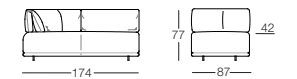
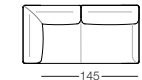
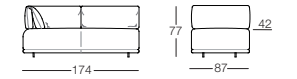

elemento con 1 bracciolo 261  
unit with 1 armrest 261

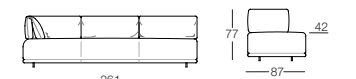

elementi angolo 261  
corner units 261

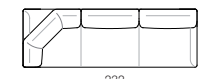
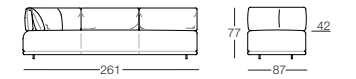
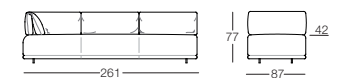

elemento senza braccioli 174  
unit without armrests 174

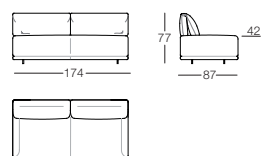

elementi isola con angolo 174  
isle units with corner unit 174

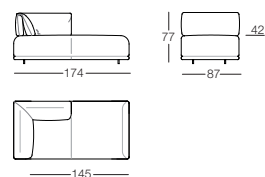

chaise longue

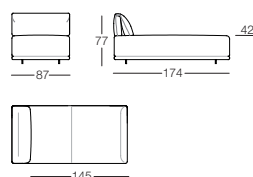

elemento isola 174  
isle unit 174

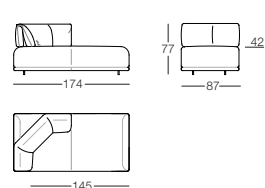
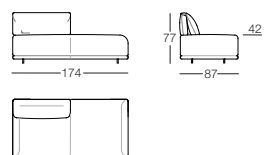

pouf

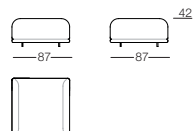

divani P.95  
sofas D.95

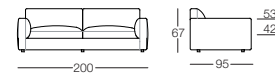

divani con braccioli alti P.95  
sofas with high armrests D.95

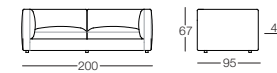

elementi con 1 bracciolo P.95  
units with 1 armrest D.95



elementi senza braccioli P.95  
units without armrests D.95

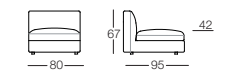

elemento isola 261  
isle unit 261

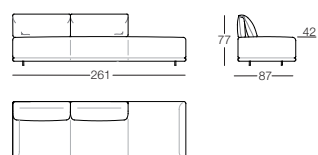

elementi isola con angolo 261  
isle units with corner unit 261

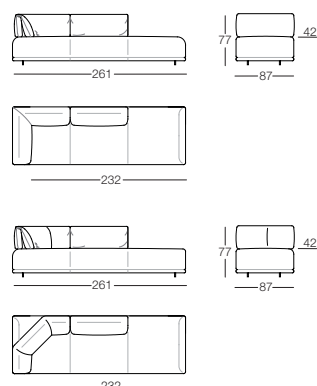

COMPOSIZIONI  
COMPOSITIONS

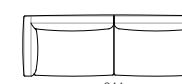
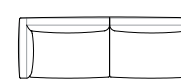
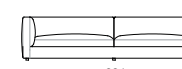
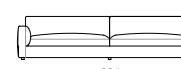
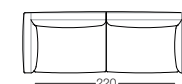
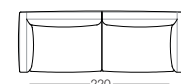
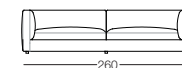
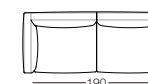
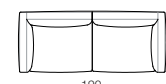
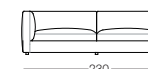
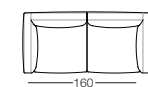
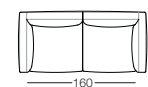
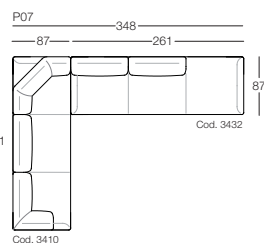
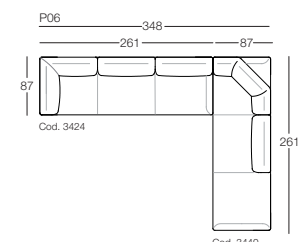
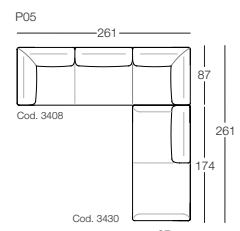
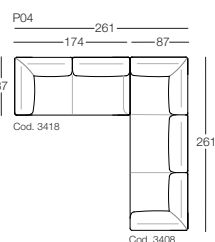
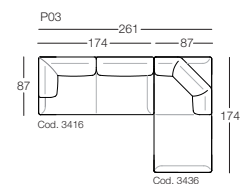
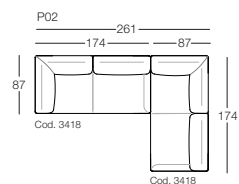
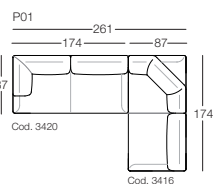

elementi con 1 bracciolo alto / angolo P.95  
units with 1 high armrest / corner unit D.95



elementi angolo con 1 bracciolo P.95  
corner units with 1 armrest D.95

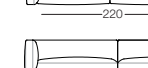
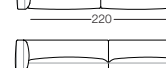
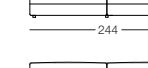
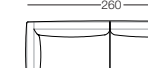
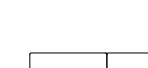
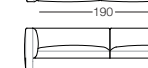
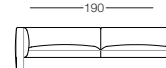
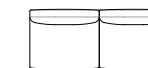
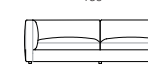
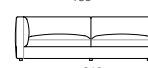
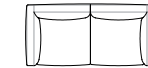
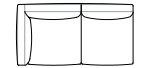
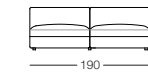
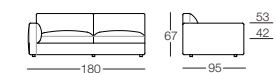
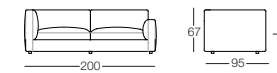



elementi isola senza bracciolo P.95  
isole units without armrest D.95

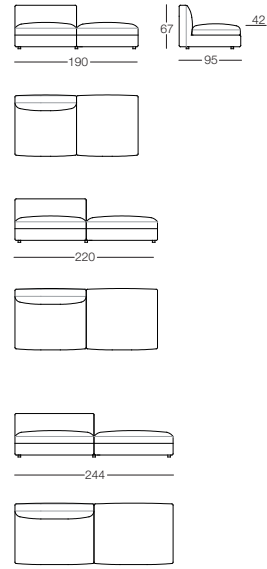

elementi isola con angolo P.95  
isole units with corner unit D.95

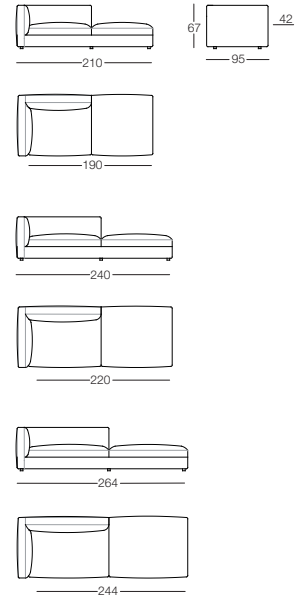

pouf

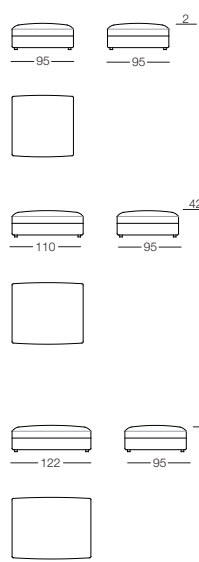

elementi senza braccioli P.120  
units without armrests D.120

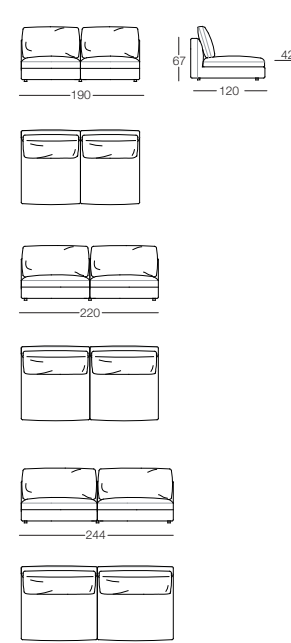

elementi isola senza braccioli P.120  
isole units without armrests D.120



elementi isola con angolo P.120  
isole units with corner unit D.120

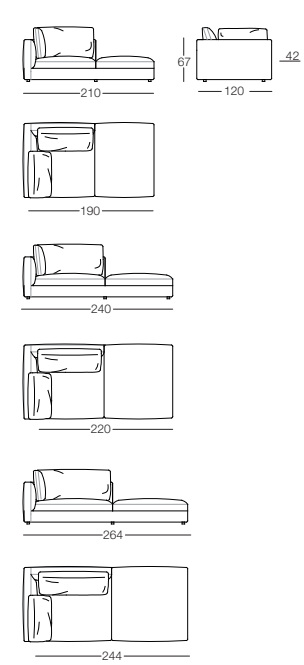

pouf

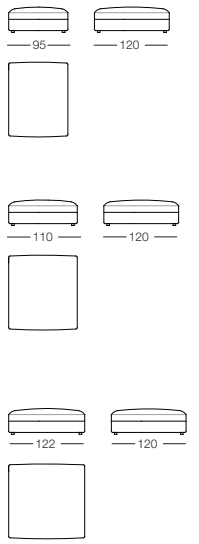

divani P.120  
sofas D.120

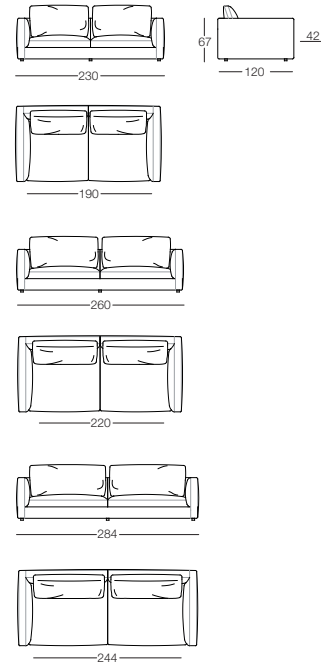

elementi con 1 bracciolo P.120  
units with 1 armrest D.120

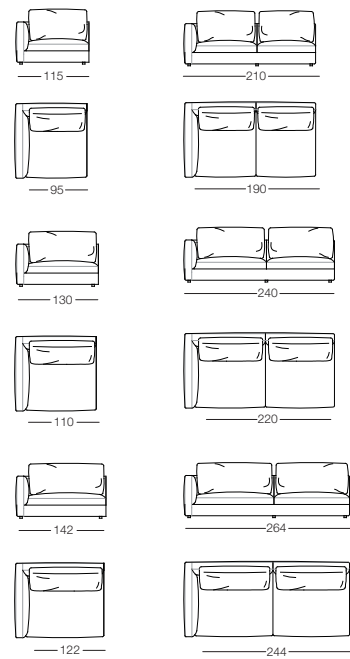

elementi senza braccioli P.120  
units without armrests D.120

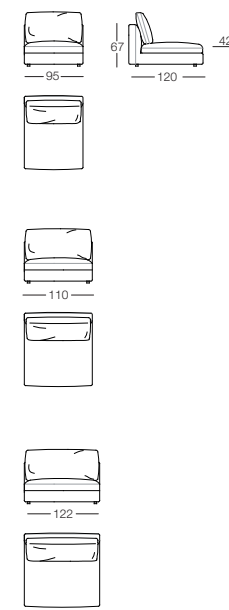

COMPOSIZIONI  
COMPOSITIONS

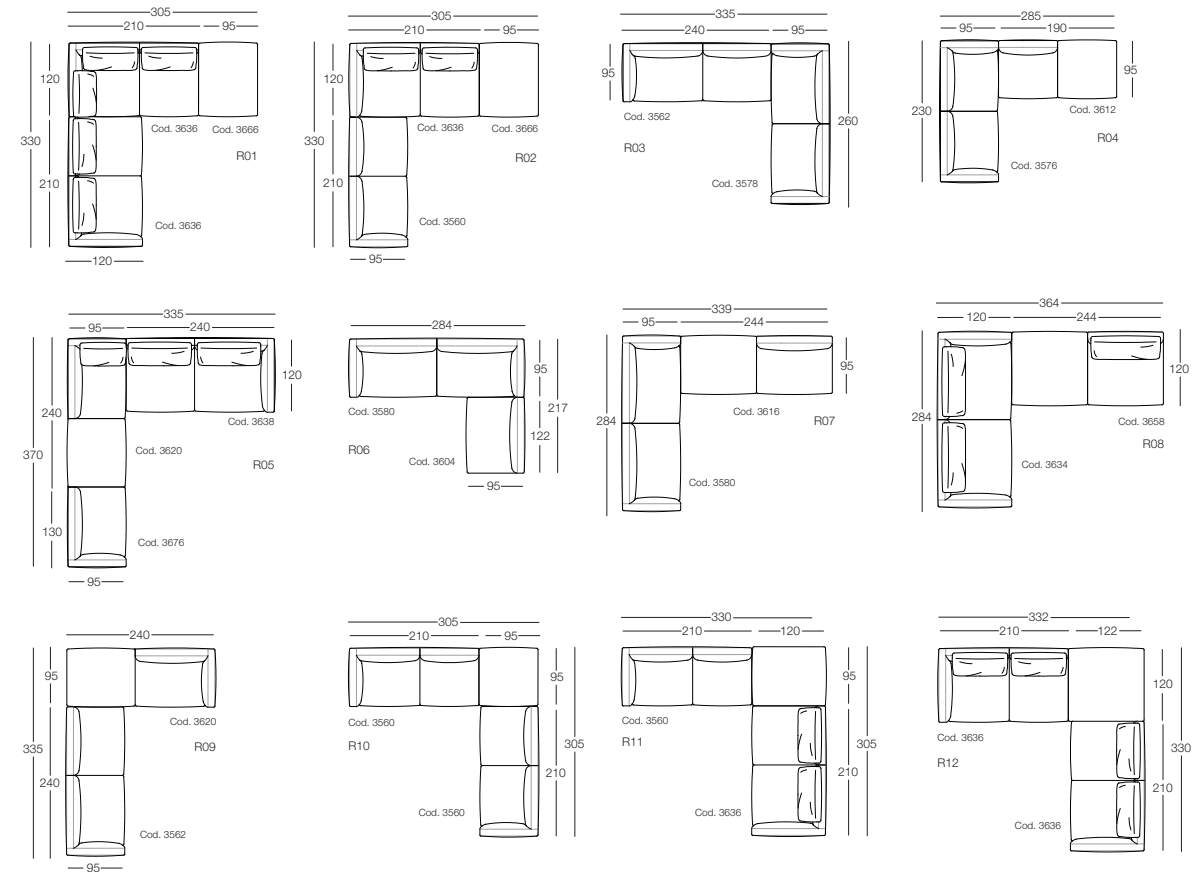

SENNA Divano\_Sofa



divani  
sofas

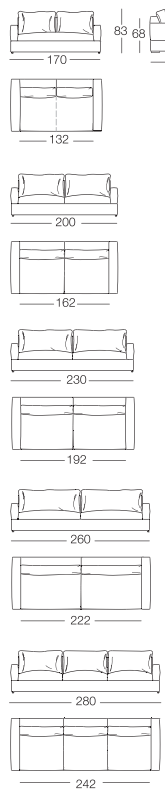

elementi con 1 bracciolo  
units with 1 armrest

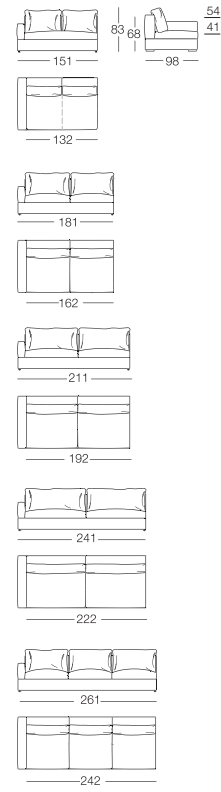

elementi senza braccioli  
units without armrests

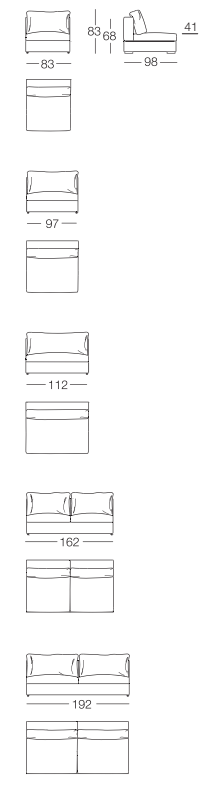

elementi angolo con 1 bracciolo  
corner units with 1 armrest

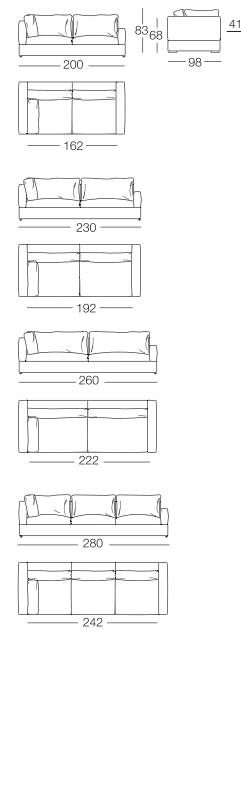

Chaise longue  
Chaise longue

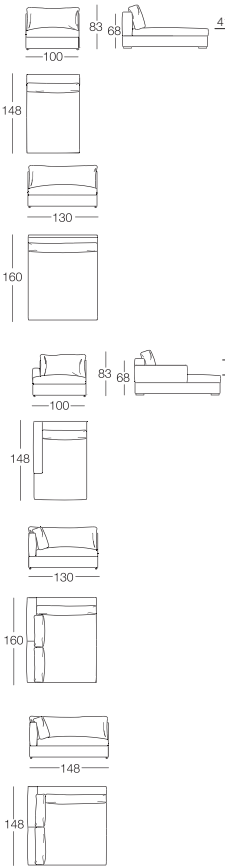

Elementi isola con 1 bracciolo  
Isle units with 1 armrest

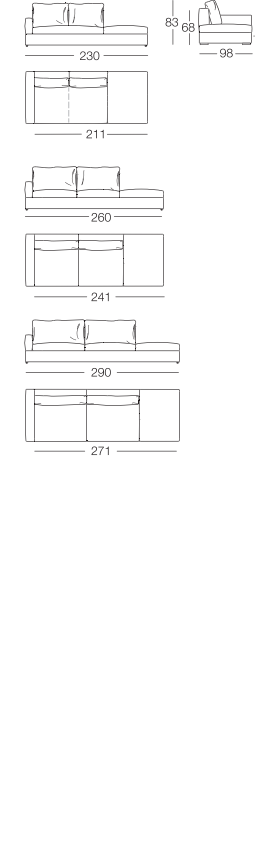

Elementi isola con angolo  
Isle units with corner

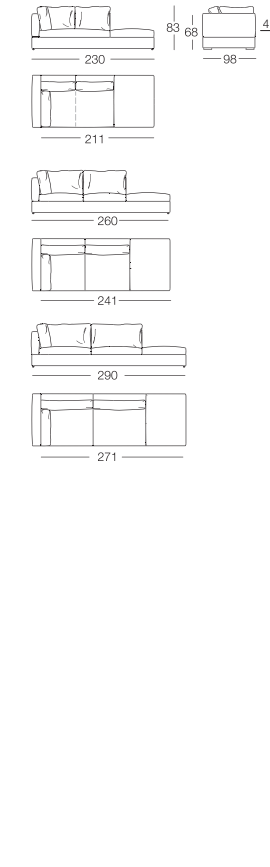

Elementi isola senza braccioli  
Isle units without armrests

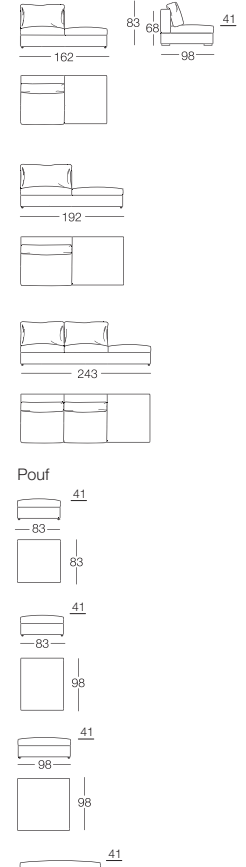

Pouf

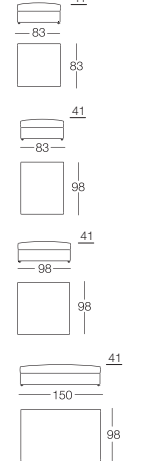

COMPOSIZIONI  
COMPOSITIONS

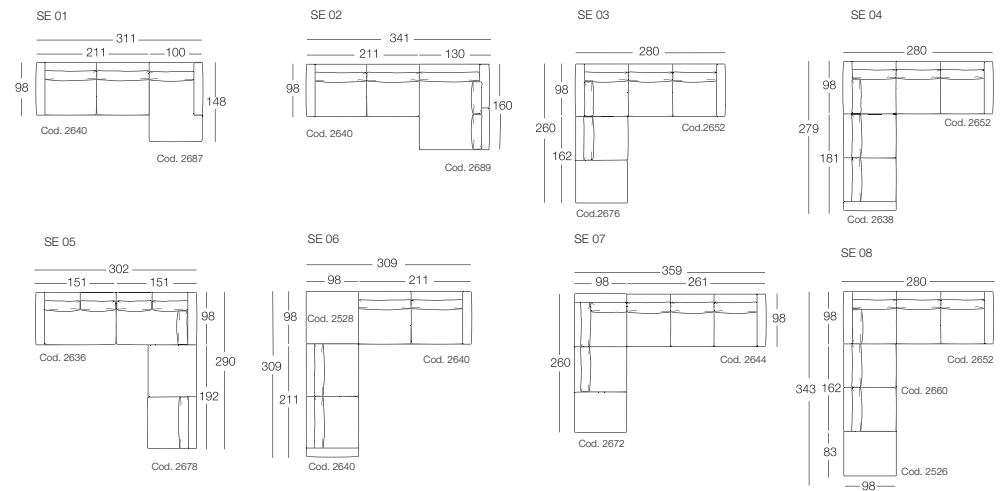



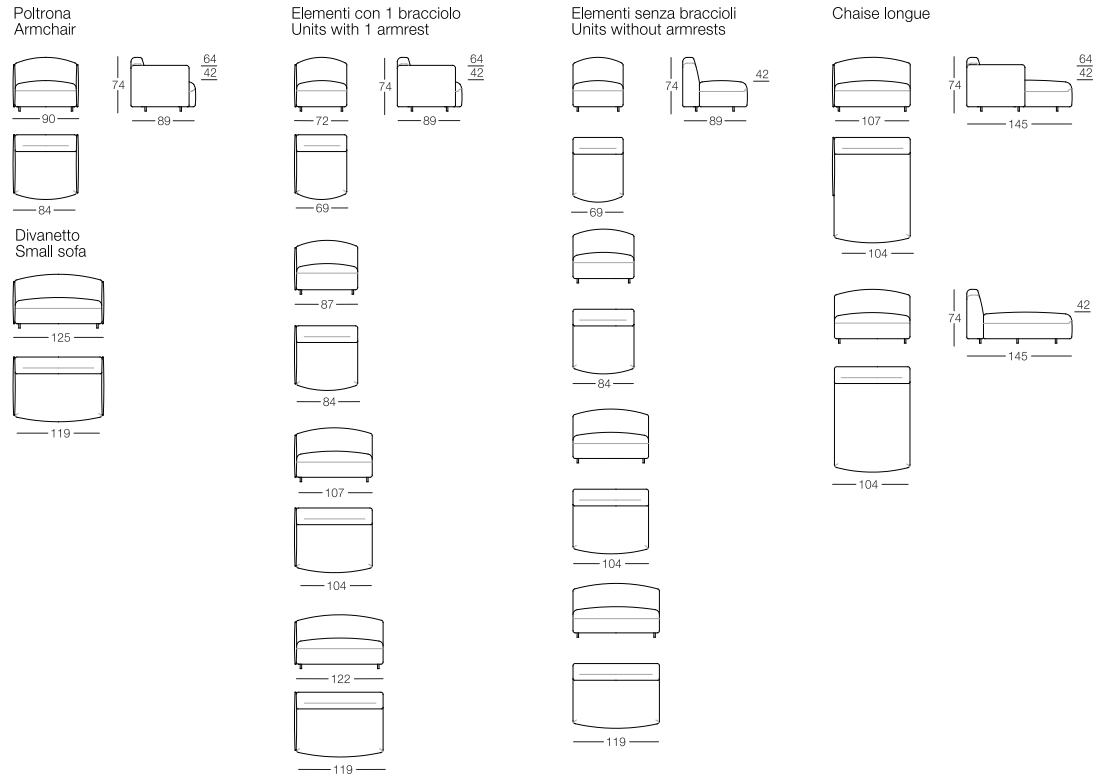

COMPOSIZIONI COMPOSITIONS

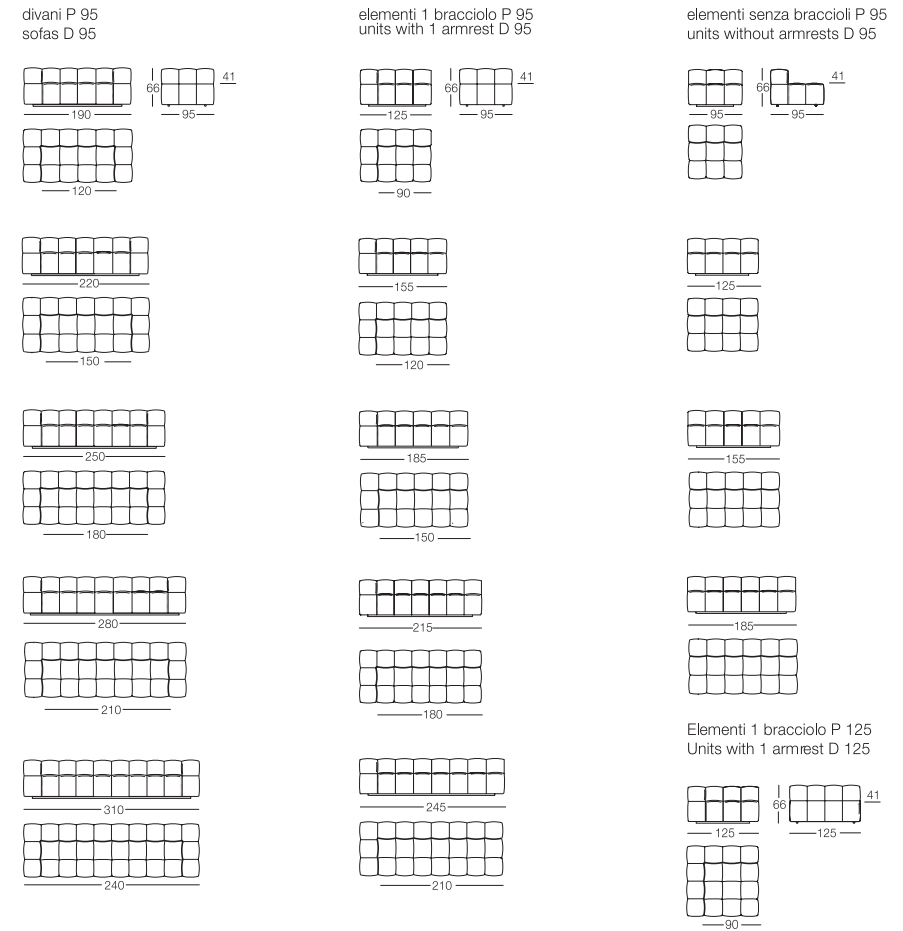
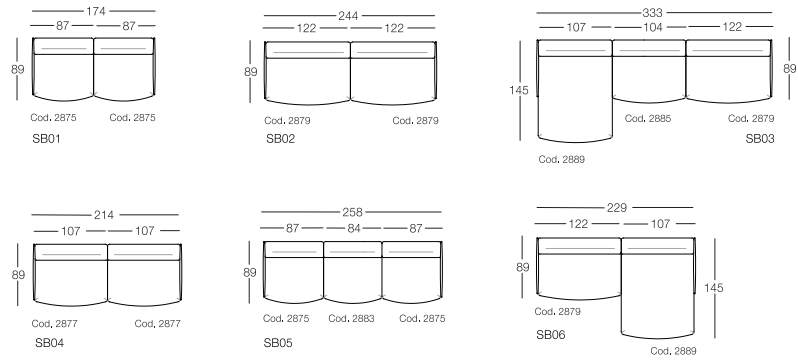

divani P 125  
sofas D 125

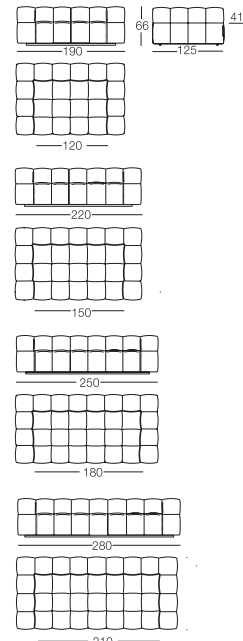

divani P 125 braccioli corti  
sofas D 125 short armrests

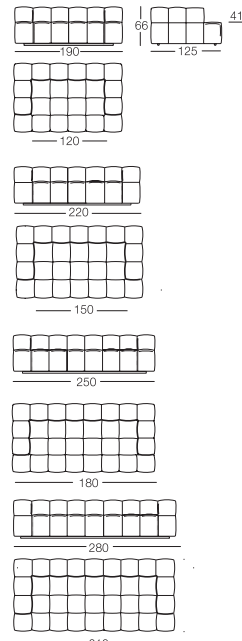

elementi 1 bracciolo P 125  
units with 1 armrest D 125

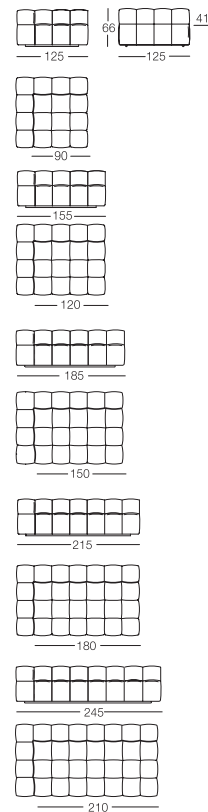

elementi senza braccioli P 125  
units without armrests D 125

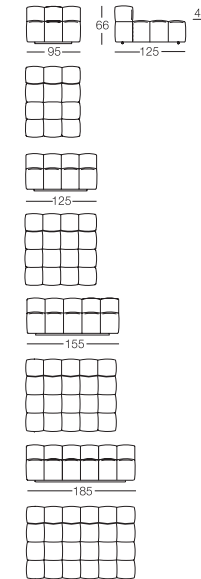

elementi 1 bracciolo corto P 125  
units with 1 short armrest D 125

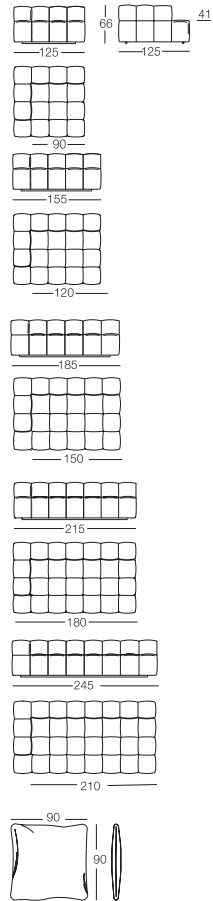

letto  
bed

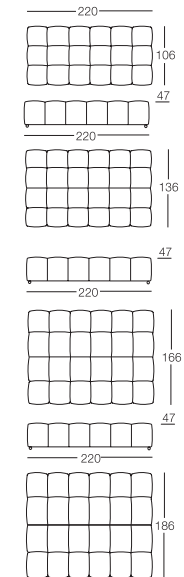

Pouf

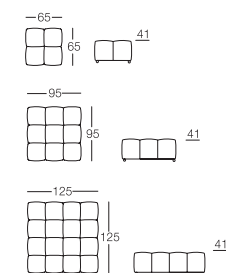

divano letto  
sofa - bed

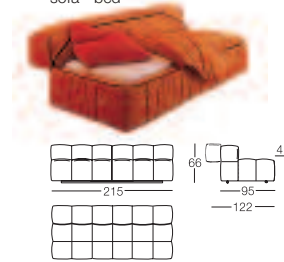

COMPOSIZIONI  
COMPOSITIONS

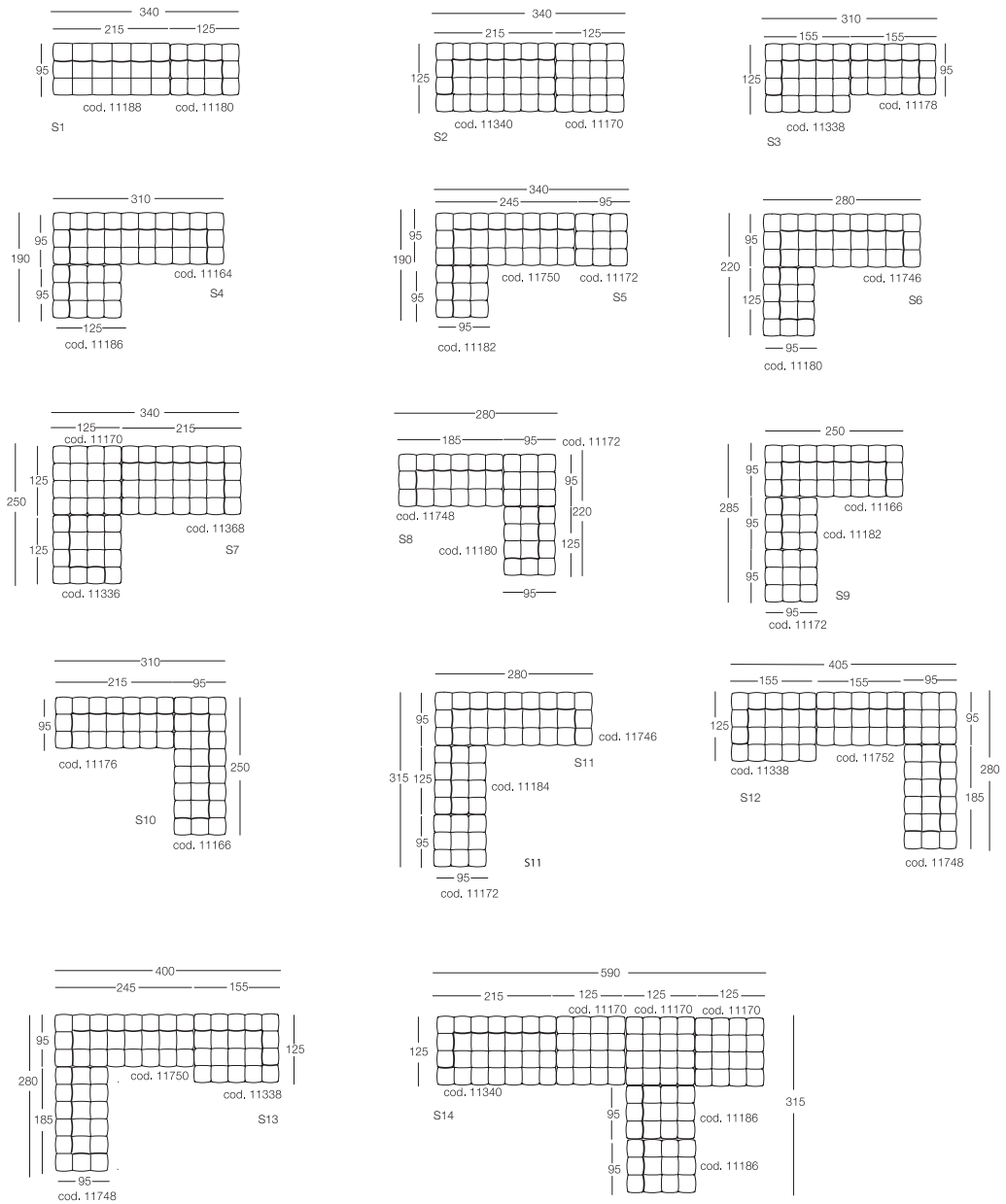



ALGON Poltrona\_Armchair

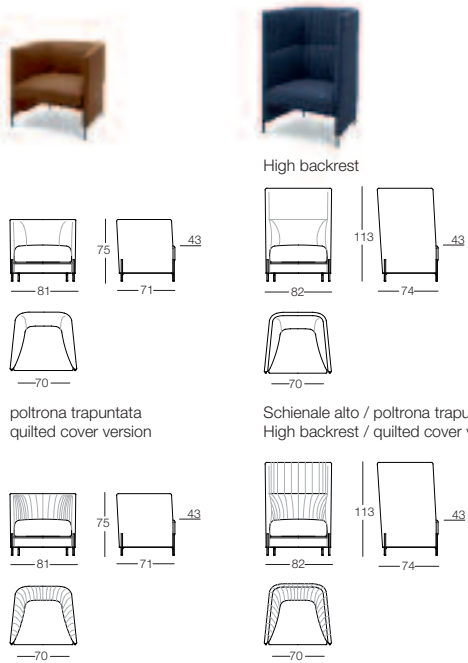

ARMILLA Poltrona\_Armchair

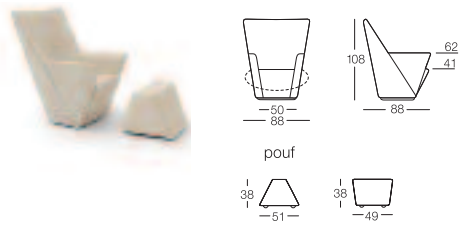

BOBORELAX Poltrona\_Armchair

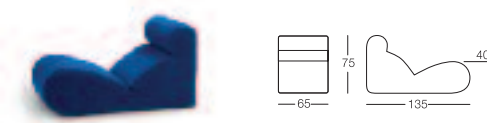

COROLLE Sedia\_Chair

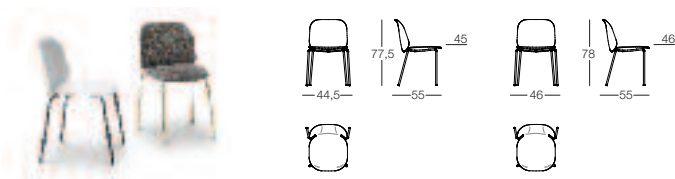

CROSS Poltrona\_Armchair

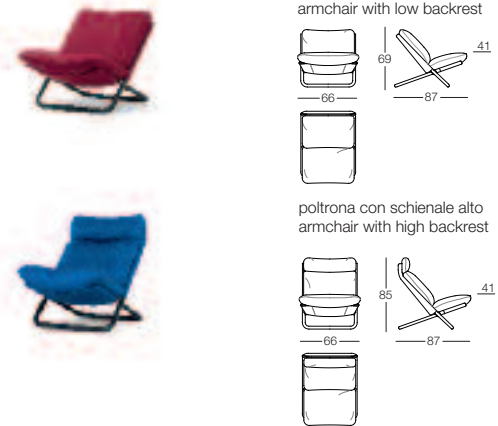

DELFINO Poltrona\_Armchair

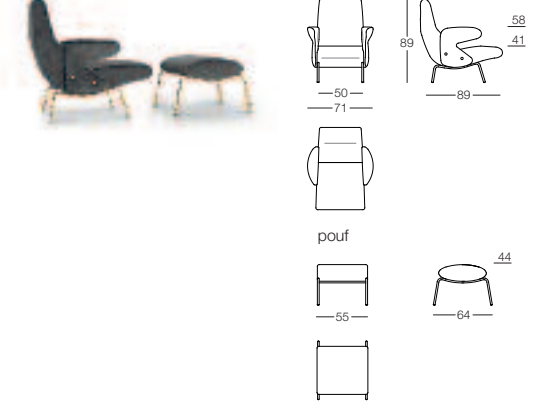

BLISS Poltrona\_Armchair

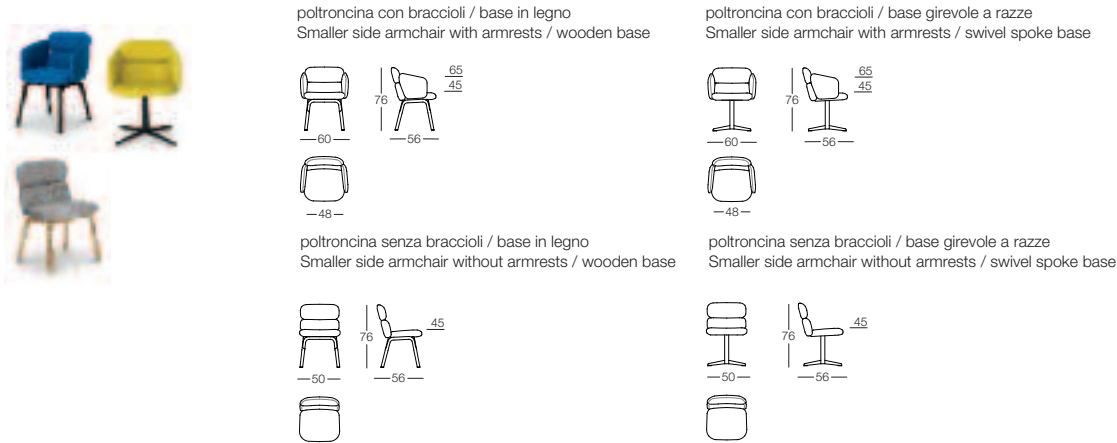

ELETTRA Poltrona\_Armchair



ELETTRA Sedia\_Chair



FEMME Poltrona\_Armchair

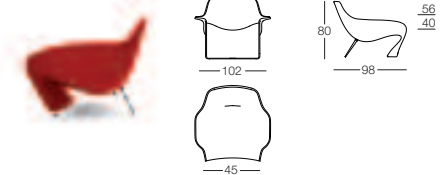

FIORENZA Poltrona\_Armchair

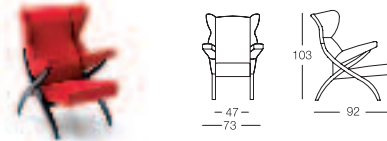

GINA Poltrona\_Armchair

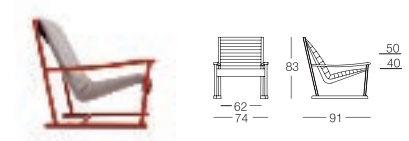

BOTOLO Poltrona\_Armchair

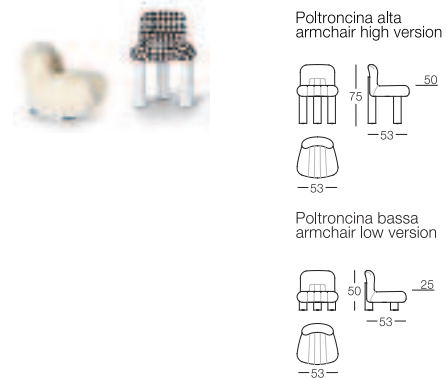

BUTTERFLY Poltrona\_Armchair



COCCA Poltrona\_Armchair



GIULIETTA Poltrona\_Armchair

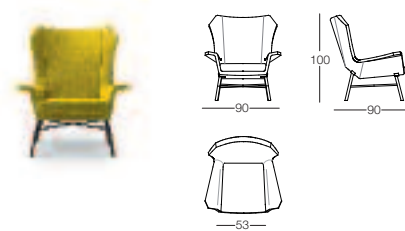

HALL Poltrona\_Armchair

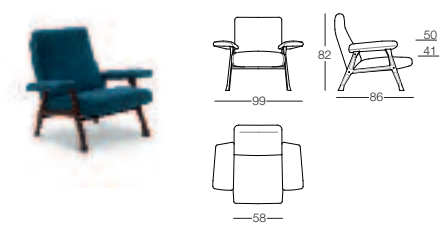

**JULES & JIM Poltrona\_Armchair**



**HUG Poltrona\_Armchair**



**LADLE Poltrona\_Armchair**

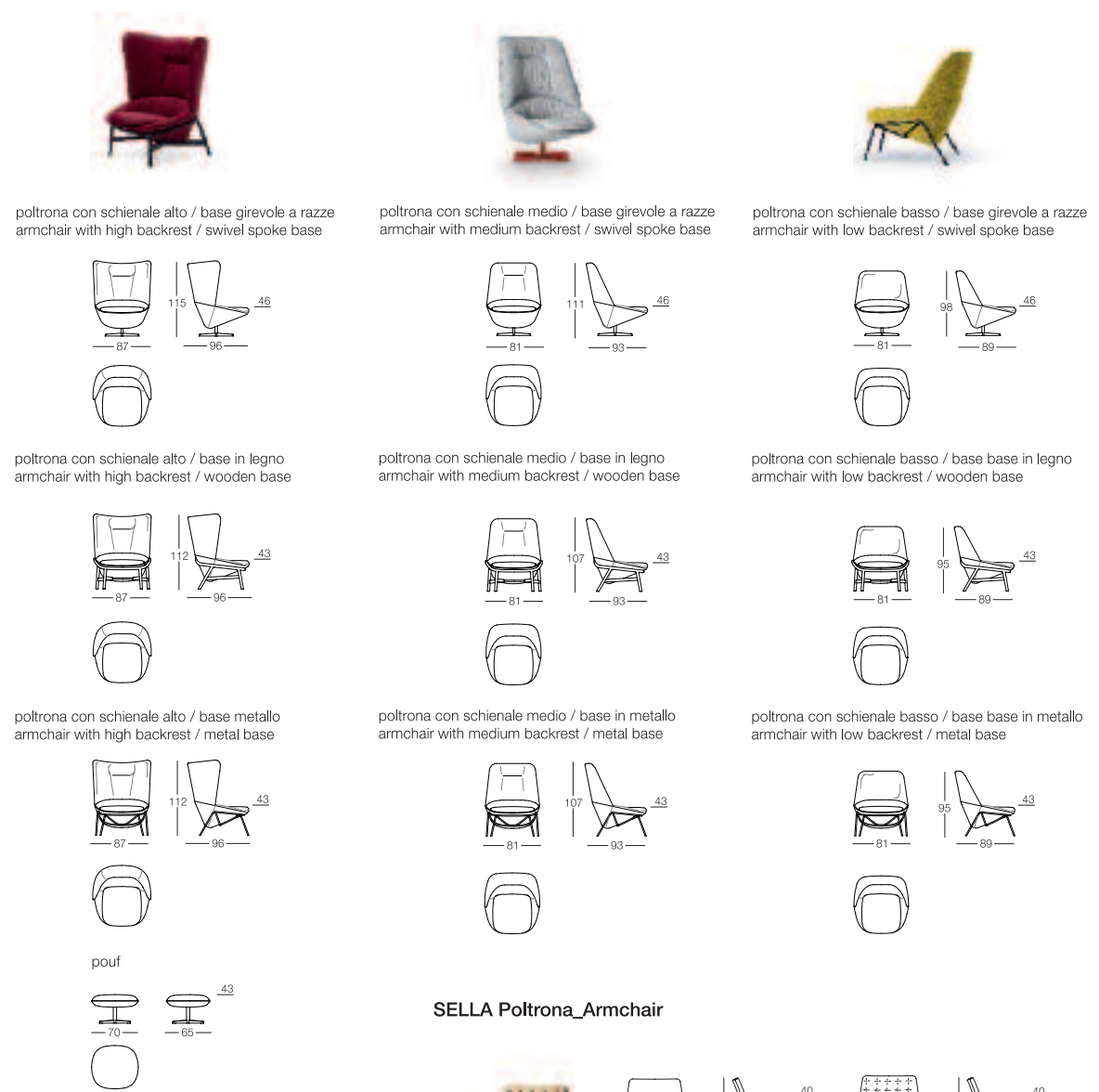

**KATRIN Poltrona\_Armchair**



**LIPS Poltrona\_Armchair**



**PECORELLE Poltrona\_Armchair**

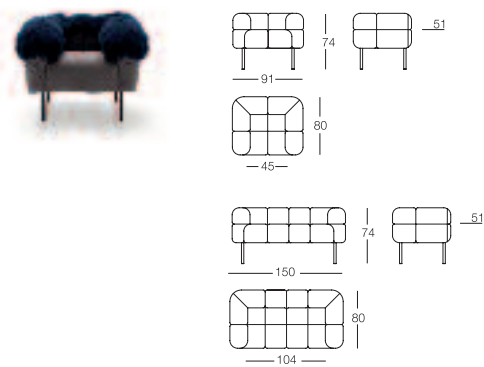

**MOJO Poltrona\_Armchair**



**NEPTUNIA Sedia\_Chair**



**SELLA Poltrona\_Armchair**

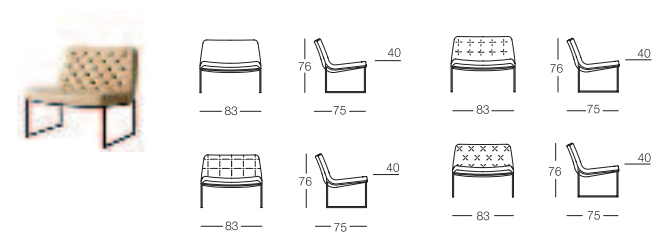

**PENTA Pouf**

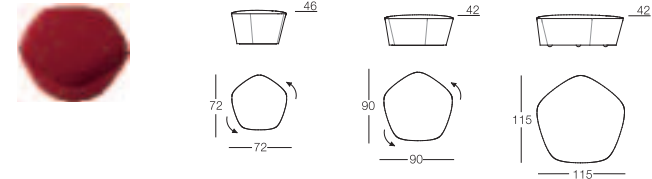

**POUF**

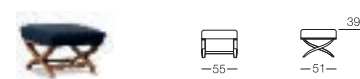

**SERENA AND DOGE Poltrona\_Armchair**

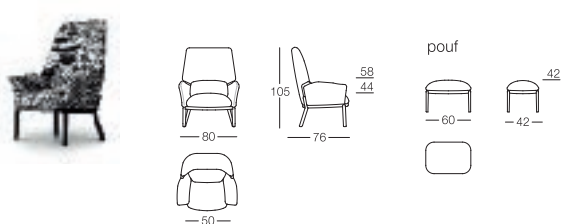



TABOGA Poltrona\_Armchair

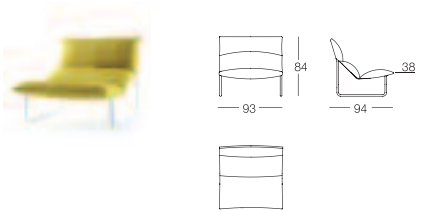

VIRGOLA Poltrona\_Armchair

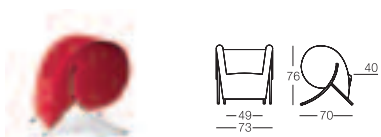

STRIPS Chaise longue

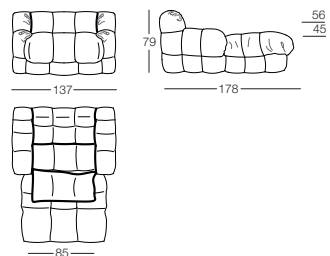

TAVOLI\_TABLES

HUG Tavolo\_Table

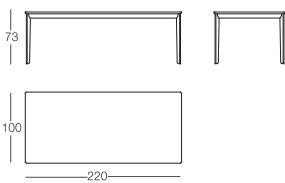

OCTOPUS Tavolo\_Table

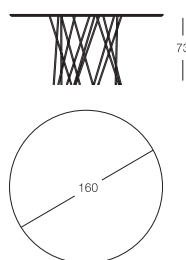

MATCH Tavolo\_Table

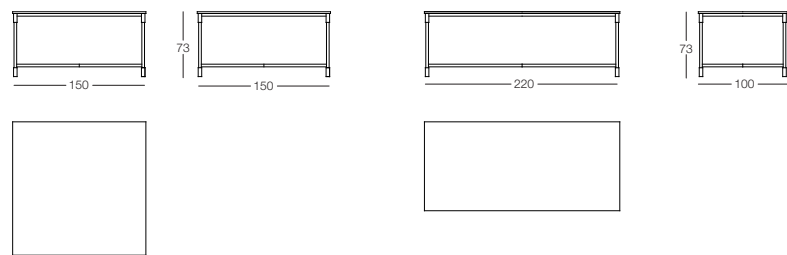

TAVOLINI E MOBILI\_SMALL TABLES AND FURNITURE UNITS

BONSAI Tavolino\_Small table



FILU' Tavolino\_Small table



Struttura Filù libreria - Bookcase frame

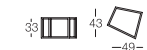

Possibili composizioni con elementi H33  
Possible compositions with elements H33



Struttura Filù libreria - Bookcase frame

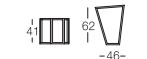

Possibili composizioni con elementi H41  
Possible compositions with elements H41

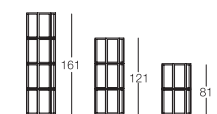

CAPILANO Tavolino\_Small table

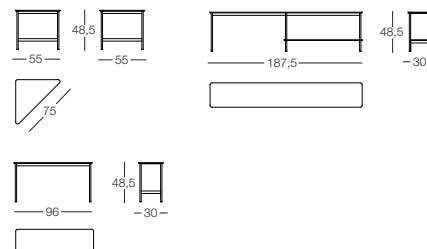

DIVA Paravento\_Screen

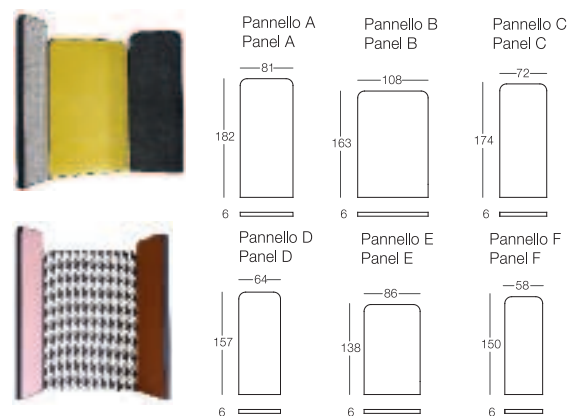

ISLAND Tavolino\_Small table

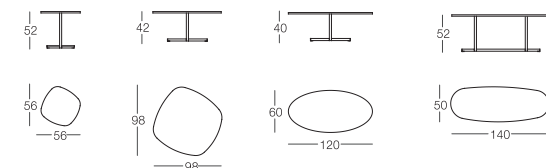

LIMITED EDITION

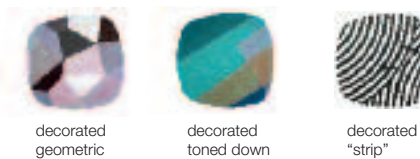

HUG Tavolino\_Small table

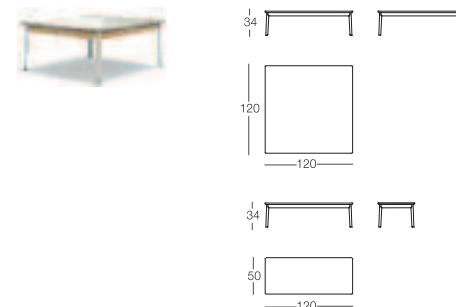

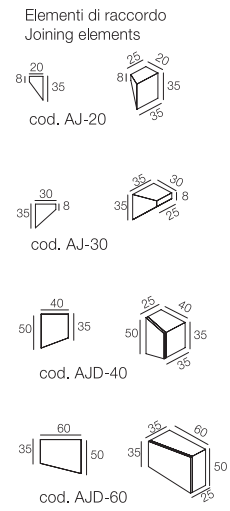
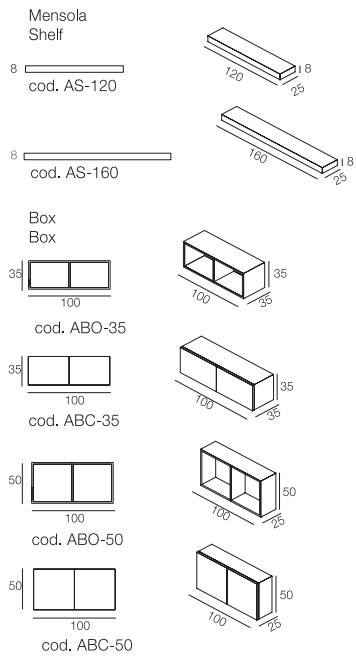

A=AIR; S=SHELF; B=BOX; O=OPEN; C=CLOSED; J=JOINT; D=WITH DOOR

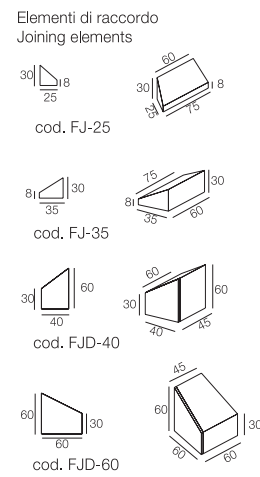
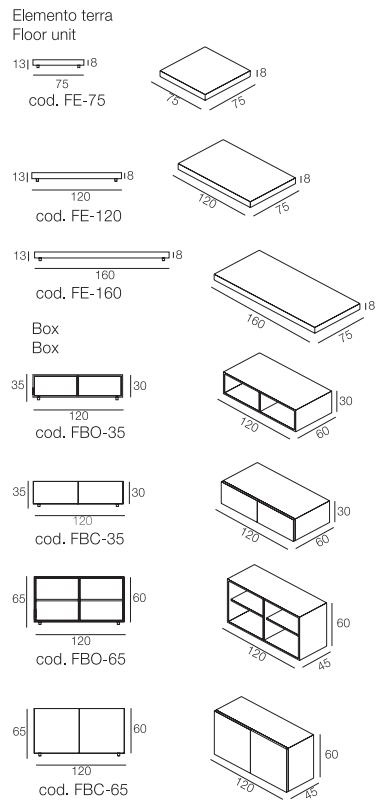

F= FLOOR; E= ELEMENT; B=BOX; O=OPEN; C=CLOSED; J=JOINT; D=WITH DOOR

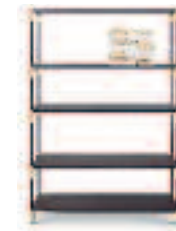

tavolini  
small tables

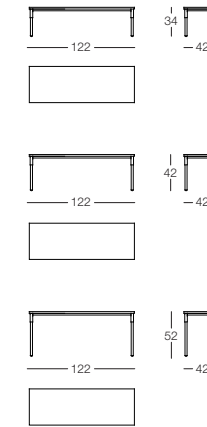

consolle

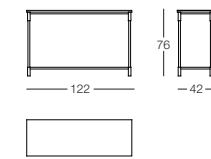

moduli per base libreria  
Element for bookcase base

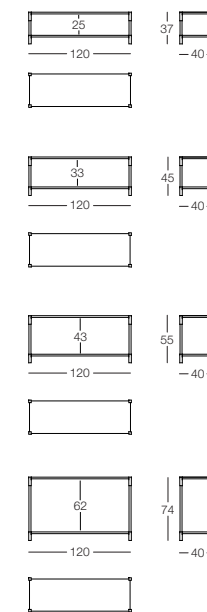

moduli in aggiunta  
Adding elements

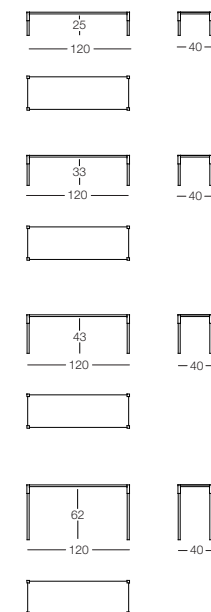

element A

element B

element C

element D

esempi composizioni librerie  
Bookcases compositions examples

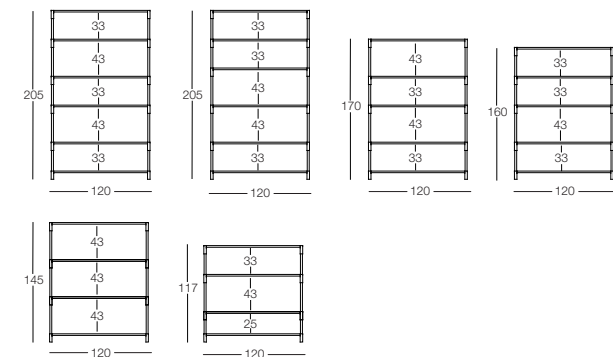



MANGOLD Tavolino\_Small table

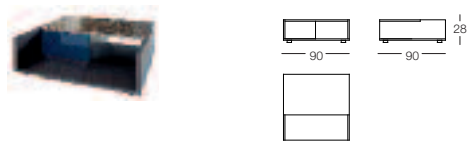

OCTOPUS Tavolino\_Small table



RUBYCON Madia\_Cabinet

madia con 2 moduli  
cabinet with 2 cubes

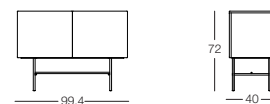

modulo  
cube

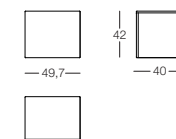

PAPILLON Lampada\_Lamp



PONTI Scrittoio\_Writing desk



madia con 3 moduli  
cabinet with 3 cubes

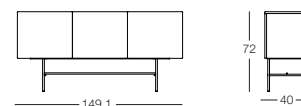

modulo bar  
bar cube

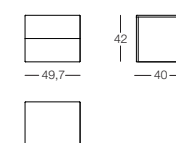

TABLET Tavolino\_Small table



VELA Paravento\_Screen

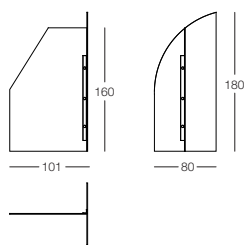

madia con 4 moduli  
cabinet with 4 cubes

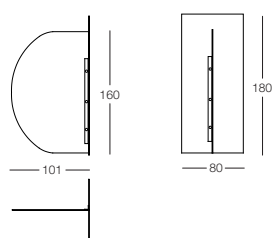
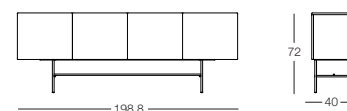

madia con 5 moduli  
cabinet with 5 cubes

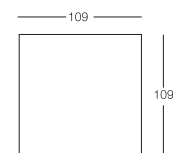
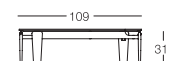
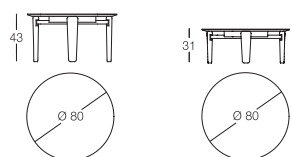
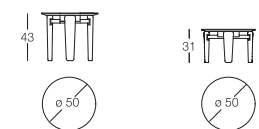
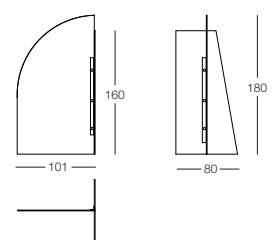
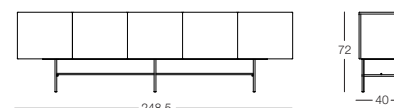

**JOY Letto\_Bed**

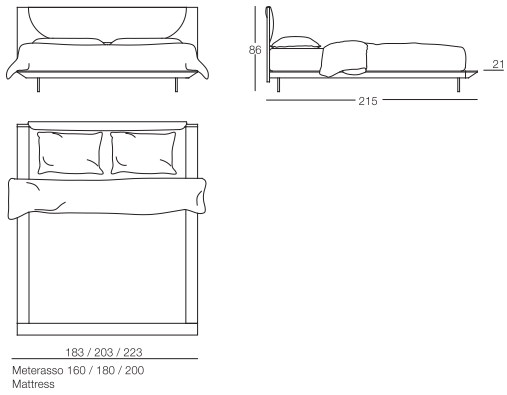

**LEDLETTO Letto\_Bed**

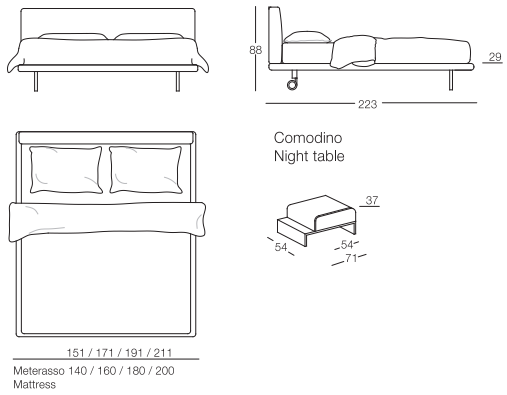

**PALAZZO Letto\_Bed**

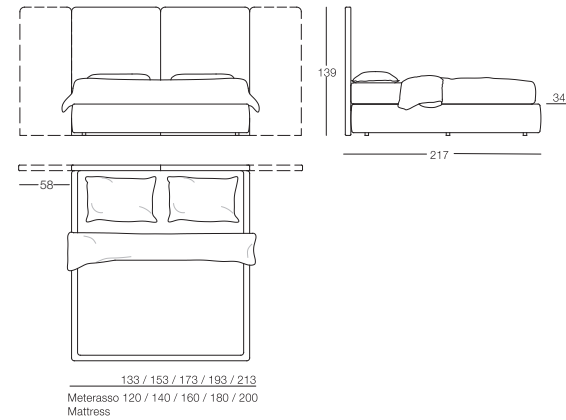

**SUITE Letto\_Bed**

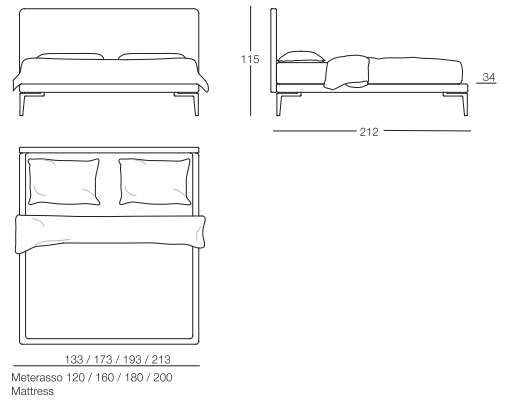

**OUTDOOR - CLOUD COLLECTION**

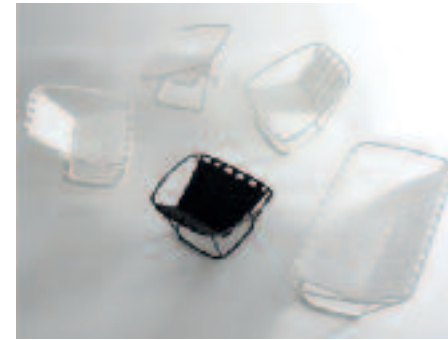

**Tavolini\_Small tables**

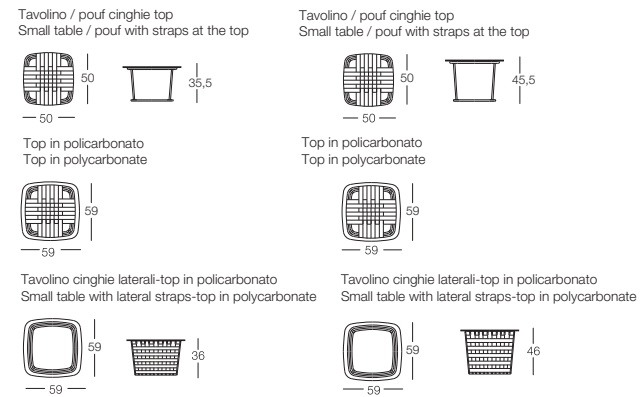

**Cocca Poltrona\_Armchair**



**Finiture\_Finishes**

**Cinghie\_Straps**

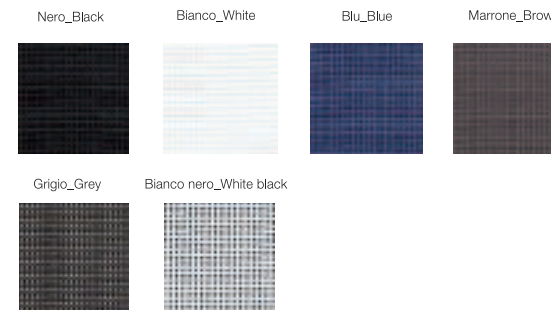

**Struttura\_Structure**

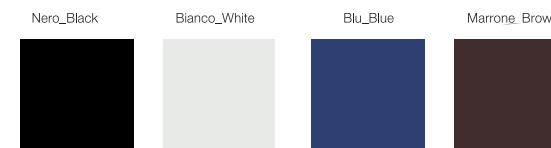

**Big**

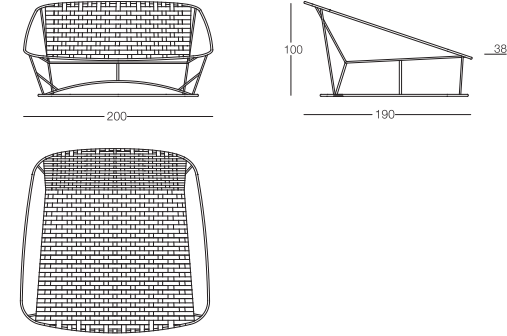

**Divanetto\_Small sofa**

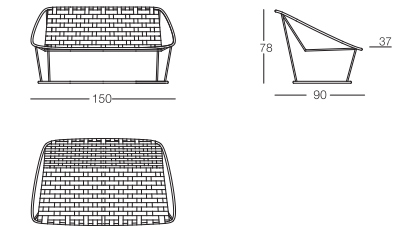

**Poltroncina\_Small armchair**

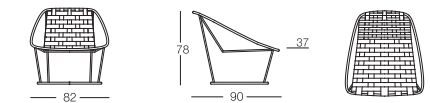

**319 #arflex**



## LACCATURA / LACQUERED

Bianco RAL 9010  
White RAL 9010

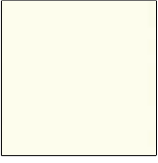

Nero RAL 9005  
Black RAL 9005



Canna di fucile  
Gun metal grey

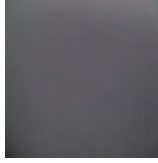

## LACCATURA OPZIONALE / OPTIONS FOR LACQUERED

Brunito  
Burnished



Giallo RAL 1032  
Yellow RAL 1032



Laguna RAL 6034  
Laguna RAL 6034



Rosso RAL 3020  
Red RAL 3020



Rosso rubino RAL 3003  
Ruby red RAL 3003



Blu RAL5010  
Blue RAL 5010



Blu notte RAL 5011  
Dark blue RAL 5011



Bronzato  
Bronzed

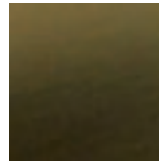

## LEGNO / WOOD

Naturale  
Natural



Rovere  
Oak



Noce Canaletto  
Walnut Canaletto



Cioccolato  
Chocolate

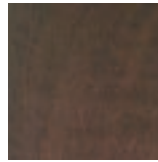

Eucalipto  
Eucalyptus



Wengè  
Wengè



## MARMO / MARBLE

Bianco Carrara  
White Carrara



Nero Marquina  
Black Marquina



Emperador  
Emperador



Calacatta oro  
Calacatta gold

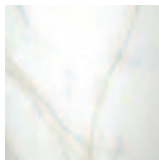

Quarzite Silver  
Quarzite Silver

